

DRIVEN and STATIC TOOLING
For
MURATEC



10139 BERGIN RD.
HOWELL, MI 48843
PHONE : 877-91-TOOLS (810-632-4446)
FAX: 877-92-TOOLS (810-632-4467)
EMAIL: info@mdtooling.com
WEBSITE: www.mdtooling.com

Live Tooling



M. T. Marchetti, a major live tool manufacturer in northern Italy, is a leader in live tool technology. The formula is simple. Use only the best angular contact high-speed bearings available. Add to this an exacting tolerances for all ground shafts, gears and bearing pocket features. Next, develop a sealed system that **will not** allow any contamination from chips or coolant.

Top this all off with a superior design and you end up with a live tool that is more rigid, faster and will last longer. **We back this up with a 2-Year factory warranty.**

Our Live Tool Warranty

Our tooling will give years of service in the most demanding applications. The superior design and rugged construction has proven this over the last 12 years. The reliability of our tools allows us to provide a 2-year factory warranty, for non-wear components.

MD Tooling will repair any defective tool holders for a period of 2 years from the date of purchase.

Product Range

We have the largest range of live tooling available for most major machine tool manufactures.

Our available products include an extensive line of standard live tooling as well as specialty tool holders such as 0-180 adjustable angle tool holders, gear hobbors, and even worm gear generators. Our product range includes geared up holders to 60,000 RPM and are engineered for 1,000 PSI coolant through.

We are an industry leader in providing complete tooling solutions with hundreds of static tool options as well.

Technical Support

Here at MD Tooling we have a full technical support department with over 35 years of CNC experience.

Our highly qualified staff can help with part processing, tooling up a job from a blue print and even assist with part programming. Applications Engineers are always available by phone to answer any questions you may have about our tooling or any other CNC related issue.

Stock and Replenishment

MD Tooling maintains an extensive inventory of tooling in our warehouse in Michigan. Our current "fill" rate on orders is 93% from our stock in Michigan for same day shipping.

Should you require a non-stock item, our manufacturer, M.T. Marchetti also maintains a large inventory in Italy. Tooling can be obtained in as little as 3-5 business days.

Shipping

MD Tooling realizes that when you need tooling, often you can't wait until the next day. We process orders and ship from available stock right up until 4PM EST to make certain we get your tooling solutions to you as quickly as possible.

We regularly ship throughout the day via UPS, FedEx or any other carrier that a customer requests.



10139 Bergin Road
Howell, MI 48843
Phone: (810) 632-4446
Fax: (810) 632-4467
Email: info@mdtooling.com
Web: www.mdtooling.com

- Fast, Friendly, Reliable Service!
- Quality tooling at highly competitive pricing.
- 2-Year Warranty on all live tools.
- Extensive inventory. We currently ship over 93% of all orders same day.
- In-house repair services available.
- If a warranty tool needs to be returned for inspection, service or repair, loaner tools are available to keep your machine tool production up and running.
- More specialty tool holders than any other manufacturer.
- Custom tool holders available.
- All available tooling may not be shown in this catalog. If you can't find the holder you're looking for, please contact our office for assistance.



Table of Contents

Categorized Listing

MT12 - MT200	1	ACCESSORIES	23
DRIVEN	1	DRIVEN	23
RADIAL DRIVEN TOOL	1	MTSK-32 ER ADAPTORS	23
AXIAL DRIVEN TOOL H=100mm	2	MTSK-32 MILL ADAPTORS	23
(0-180) ADJUSTABLE ANGLE DRIVEN TOOL H=74mm	3	POLYGON MAKING MILL HEAD (2 INSERTS)	24
DRIVEN GEAR HOBBER	4	POLYGON MAKING MILL HEAD (3 INSERTS)	24
STATIC	5		
RADIAL SINGLE STATIC TOOL	5		
RADIAL BLADE HOLDER WITH BLADE KIT	5		
RADIAL BLADE HOLDER WITH INTERNAL COOLANT - BLADE KIT NOT INCLUDED	5		
AXIAL SINGLE STATIC TOOL	6		
AXIAL SINGLE BORING BAR HOLDER H=95mm	6		
MD60 - MD120	7		
DRIVEN	7		
RADIAL DRIVEN TOOL	7		
AXIAL DRIVEN TOOL H=100mm	8		
AXIAL GEARED-UP 1:2 DRIVEN TOOL H=100mm	8		
(0-180) ADJUSTABLE ANGLE DRIVEN TOOL H=74mm	9		
STATIC	10		
RADIAL SINGLE STATIC TOOL	10		
RADIAL BLADE HOLDER WITH BLADE KIT	10		
RADIAL BLADE HOLDER WITH INTERNAL COOLANT - BLADE KIT NOT INCLUDED	10		
AXIAL SINGLE STATIC TOOL	11		
AXIAL SINGLE BORING BAR HOLDER H=95mm	11		
MT100 15ST.	12		
DRIVEN	12		
RADIAL REINFORCED DRIVEN TOOL	12		
QUICK CHANGE RADIAL MTSK DRIVEN TOOL	12		
See Accessories for MTSK Adaptors	12		
RADIAL DRIVEN TOOL REDIRECTED IN Z BY 36mm	13		
RADIAL GEARED-DOWN 2:1 DRIVEN TOOL REDIRECTED IN Z BY 43mm	13		
RADIAL GEARED-DOWN 2:1 DRIVEN TOOL REDIRECTED IN Z BY 60mm	14		
RADIAL GEARED-DOWN 3:1 DRIVEN TOOL REDIRECTED IN Z BY 60mm	14		
RADIAL GEARED-UP 1:2 DRIVEN TOOL REDIRECTED IN Z BY 36mm	15		
RADIAL SINGLE SIDE TWIN HEAD DRIVEN TOOL IN Y	15		
AXIAL DRIVEN TOOL H=60mm	16		
QUICK CHANGE AXIAL MTSK DRIVEN TOOL H=60mm	16		
See Accessories for MTSK Adaptors	16		
AXIAL GEARED-UP 1:2 DRIVEN TOOL	17		
AXIAL GEARED-UP 1:3 REAR-SET DRIVEN TOOL H=65mm	17		
AXIAL DRIVEN TOOL FOR INTERNAL POLYGON-MAKING H=60mm	18		
See Accessories for Mill Heads	18		
AXIAL OPPOSITE FACE TWIN DRIVEN TOOL H=60mm	18		
AXIAL SINGLE SIDE TWIN HEAD DRIVEN TOOL IN Y	19		
(0-180) ADJUSTABLE ANGLE DRIVEN TOOL	19		
DRIVEN GEAR HOBBER	20		
BROACHING/SLOTTING DRIVEN TOOL 25mm STROKE H=65mm	20		
STATIC	21		
RADIAL SINGLE STATIC TOOL	21		
RADIAL DOUBLE STATIC TOOL	21		
RADIAL BLADE HOLDER WITH BLADE KIT	21		
AXIAL SINGLE STATIC TOOL	22		
AXIAL SINGLE BORING BAR HOLDER H=60mm	22		
AXIAL SINGLE BORING BAR HOLDER H=70mm	22		

MT12 - MT200

DRIVEN

RADIAL DRIVEN TOOL

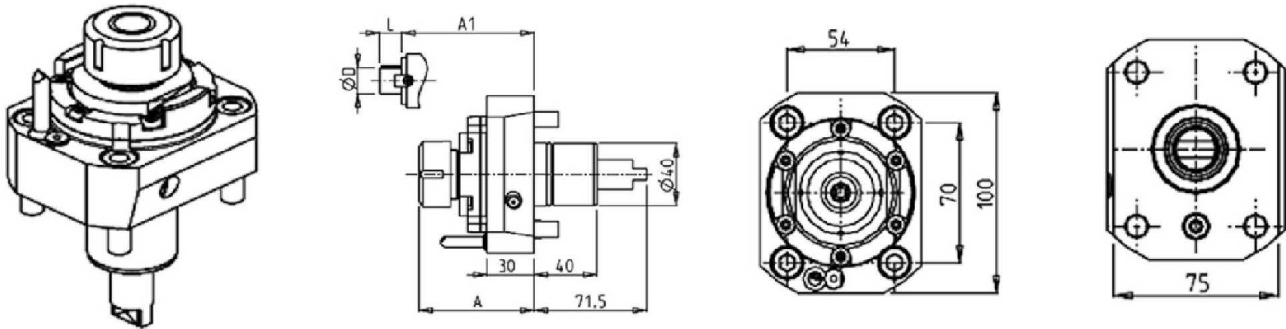

Part Number	Description	Spindle	I	RPM	Cool Thru	Ext Cool	A	A1	D	L	Price
MUR0050125	Radial Driven Tool ER25	ER25	1:1	6000		X	73.16				\$2,425
MUR0050225	Radial Driven Tool ER25 Cool Thru*	ER25	1:1	6000	X	X	88.16				\$3,175
MUR0050325	Radial Driven Tool ERA25	ERA25	1:1	6000		X	59.5				\$2,425
MUR0050425	Radial Driven Tool ERA25 Cool Thru*	ERA25	1:1	6000	X	X	74.5				\$3,175
MUR0050132	Radial Driven Tool ER32	ER32	1:1	6000		X	76.16				\$2,425
MUR0050232	Radial Driven Tool ER32 Cool Thru*	ER32	1:1	6000	X	X	91.16				\$3,175
MUR0050516	Radial Driven Tool 16x17mm	16x17	1:1	6000		X		54.5	16	17	\$2,750

*Coolant Thru tools are designed for 400 psi MAX.
They require 5 Micron Filtration and **CANNOT** be run dry.

MT12 - MT200

DRIVEN

AXIAL DRIVEN TOOL H=100mm

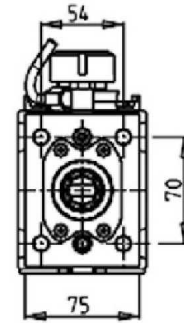
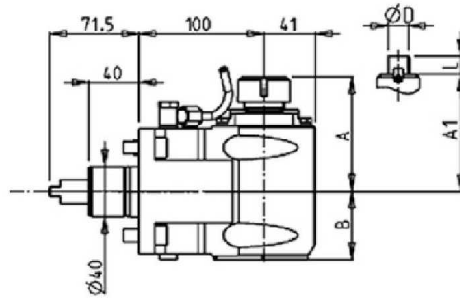
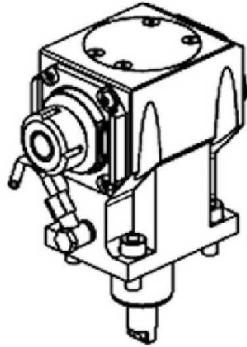

Part Number	Description	Spindle	I	RPM	Reversible	Cool Thru	Ext Cool	A	A1	B	Price
MUR0030125	Axial Driven Tool ER25	ER25	1:1	6000	X		X	91.16	54.5		\$4,375
MUR0030225	Axial Driven Tool ER25 Cool Thru*	ER25	1:1	6000	X	X	X	91.16	65.5		\$4,925
MUR0030325	Axial Driven Tool ERA25	ERA25	1:1	6000	X		X	65	54.5		\$4,375
MUR0030425	Axial Driven Tool ERA25 Cool Thru*	ERA25	1:1	6000	X	X	X	65	65.5		\$4,925
MUR0030132	Axial Driven Tool ER32	ER32	1:1	6000	X		X	93.66	54.5		\$4,375
MUR0030232	Axial Driven Tool ER32 Cool Thru*	ER32	1:1	6000	X	X	X	93.66	65.5		\$4,925
MUR0030140	Axial Driven Tool ER40	ER40	1:1	6000	X		X	98.16	54.5		\$4,375
MUR0030240	Axial Driven Tool ER40 Cool Thru*	ER40	1:1	6000	X	X	X	98.16	65.5		\$4,925
MUR0030516	Axial Driven Tool 16x17mm	16x17	1:1	6000	X		X		67.5	54.5	\$4,795
MUR0030522	Axial Driven Tool 22x19mm	22x19	1:1	6000	X		X		67.5	54.5	\$4,795
MUR0030527	Axial Driven Tool 27x21mm	27x21	1:1	6000	X		X		70	54.5	\$4,795

* Coolant Thru tools are designed for 1000 psi.
They require 5 Micron Filtration and **CANNOT** be run dry.

MT12 - MT200

DRIVEN

(0-180) ADJUSTABLE ANGLE DRIVEN TOOL H=74mm

It is not possible to make machining operations at the center of the part with tool oriented at 0° or at 180°

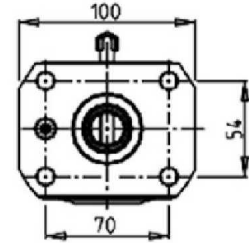
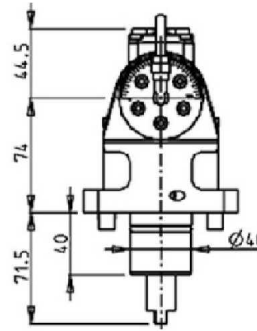
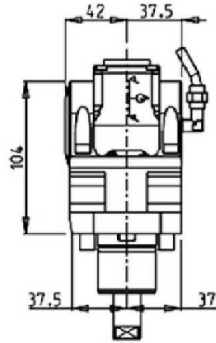
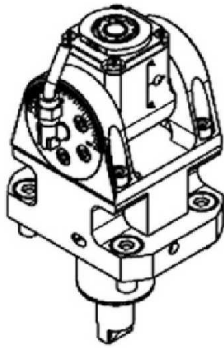

Part Number	Description	Spindle	I	RPM	Reversible	Cool Thru	Ext Cool	Price
MUR0070116	(0-180) Adj. Angle Driven Tool ERA16	ERA16	1:1	6000	X		X	\$7,150
MUR0070216	(0-180) Adj. Angle Driven Tool ERA16 Cool Thru*	ERA16	1:1	6000	X	X	X	\$7,995

* Coolant Thru tools are designed for 1000 psi.
They require 5 Micron Filtration and **CANNOT** be run dry.

Note :

Wrenches are provided with the purchase of Specialty Toolholders

MT12 - MT200

DRIVEN

DRIVEN GEAR HOBBER New

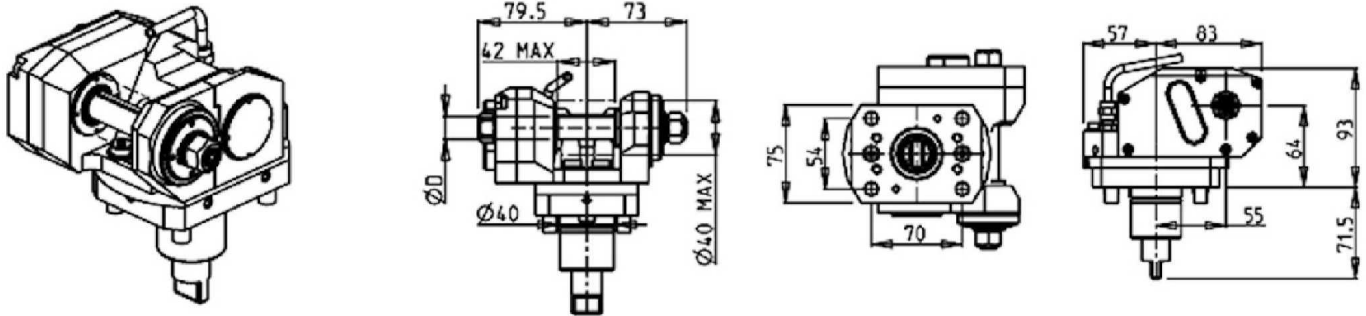

Part Number	Description	I	MAX RPM	Ext Cool	D	Price
MUR0211108	Driven Gear Hobb 1:1 D=8mm	1:1	6000	X	8	\$7,795
MUR0211110	Driven Gear Hobb 1:1 D=10mm	1:1	6000	X	10	\$7,795
MUR0211113	Driven Gear Hobb 1:1 D=13mm	1:1	6000	X	13	\$7,795
MUR0211116	Driven Gear Hobb 1:1 D=16mm	1:1	6000	X	16	\$7,795
MUR0211155	Driven Gear Hobb 1:1 D=1/2"	1:1	6000	X	1/2"	\$7,795
MUR0212108	Driven Gear Hobb Geared-Down 2:1 D=8mm	2:1	3000	X	8	\$7,895
MUR0212110	Driven Gear Hobb Geared-Down 2:1 D=10mm	2:1	3000	X	10	\$7,895
MUR0212113	Driven Gear Hobb Geared-Down 2:1 D=13mm	2:1	3000	X	13	\$7,895
MUR0212116	Driven Gear Hobb Geared-Down 2:1 D=16mm	2:1	3000	X	16	\$7,895
MUR0212155	Driven Gear Hobb Geared-Down 2:1 D=1/2"	2:1	3000	X	1/2"	\$7,895

Note : Wrenches are provided with the purchase of Specialty Toolholders

MT12 - MT200

STATIC

RADIAL SINGLE STATIC TOOL New

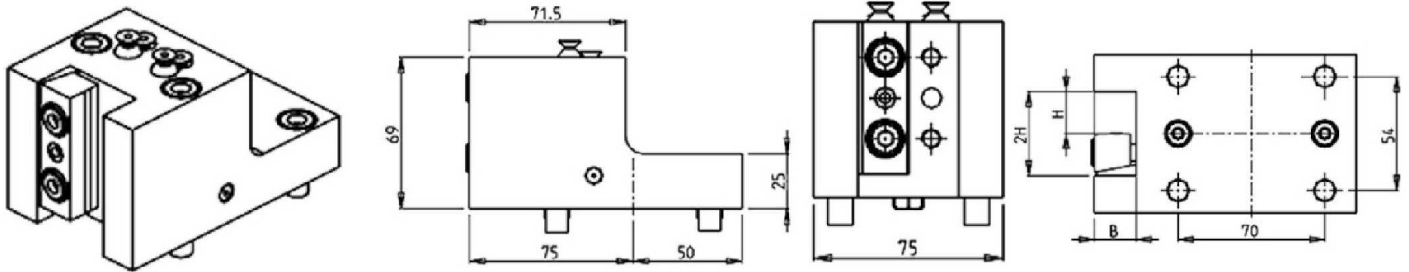

Part Number	Description	# of Tools	Cool Thru	Ext Cool	Dimensions	B	H	Price
MUR0162000	Radial Single Static Tool 20mm	1		X	mm	20	20	\$750
MUR0162010	Radial Single Static Tool 20mm Cool Thru*	1	X	X	mm	20	20	\$895

RADIAL BLADE HOLDER WITH BLADE KIT New

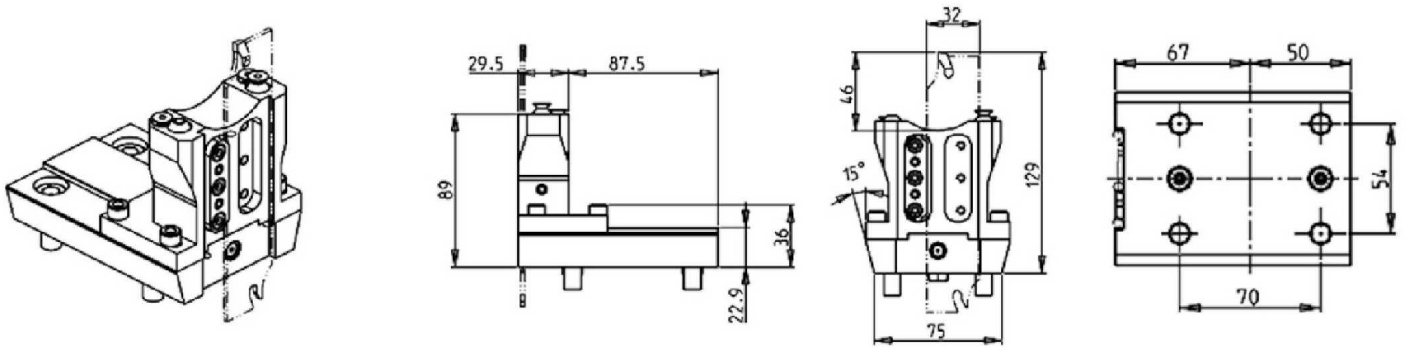

Part Number	Description	# of Tools	Reversible	Ext Cool	Price
MUR0190132	Radial Blade Holder with Blade Kit	1	X	X	\$1,050
BLADEKIT	Blade Kit: 1 Blade, 10 Inserts				\$395

RADIAL BLADE HOLDER WITH INTERNAL COOLANT - BLADE KIT NOT INCLUDED New

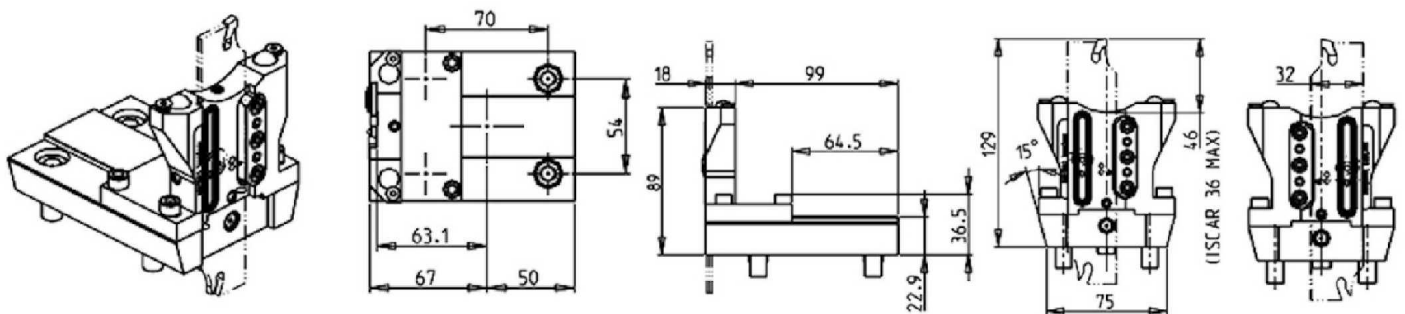

Part Number	Description	# of Tools	Ext Cool	Cool Thru	Price
MUR0200132R	Radial Blade Holder Cool Thru (Right Hand)	1	X	X	\$995
MUR0200132L	Radial Blade Holder Cool Thru (Left Hand)	1	X	X	\$995
COOL THRU BLADEKIT	Blade Kit: 1 Blade, 10 Inserts				\$550

MT12 - MT200

STATIC

AXIAL SINGLE STATIC TOOL New

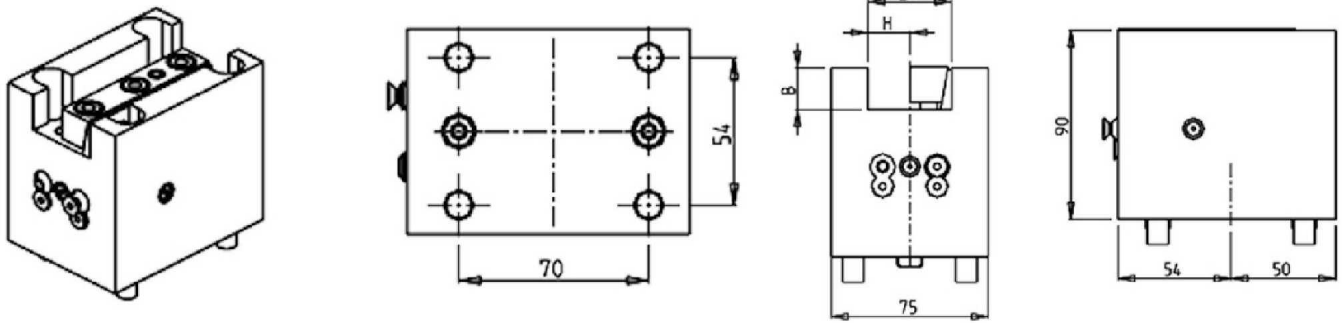

Part Number	Description	# of Tools	Cool Thru	Ext Cool	Dimensions	B	H	Price
MUR0172000	Axial Single Static Tool 20mm	1		X	mm	20	20	\$775
MUR0172010	Axial Single Static Tool 20mm Cool Thru*	1	X	X	mm	20	20	\$925

AXIAL SINGLE BORING BAR HOLDER H=95mm New

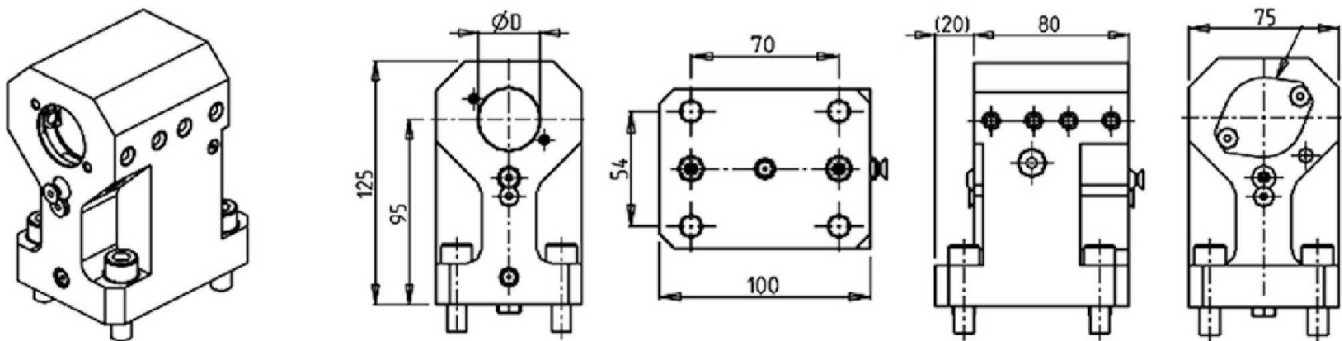

Part Number	Description	# of Tools	Reversible	Cool Thru	Ext Cool	Dimensions	D	Price
MUR0183200	Axial Single BBH 32mm	1	X	X	X	mm	32	\$825
KIT1000001	Plug for 32mm or 1-1/4" BBH to Make Cool Thru							\$75

MD60 - MD120

DRIVEN

RADIAL DRIVEN TOOL

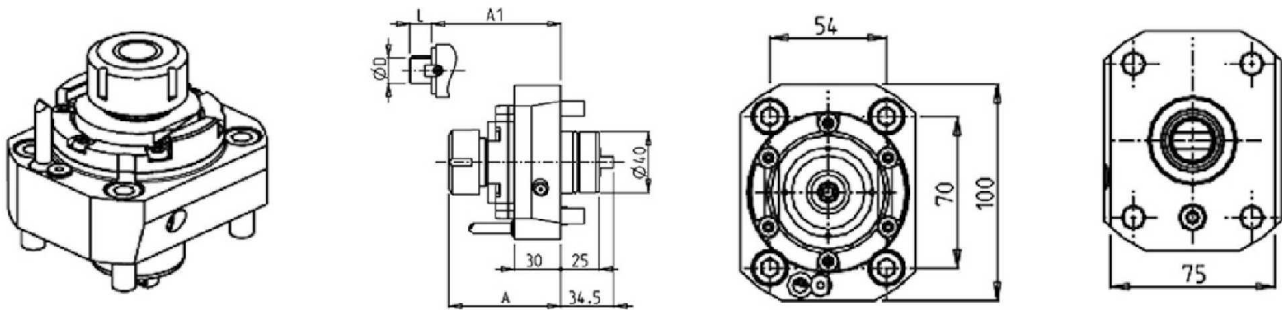

Part Number	Description	Spindle	I	RPM	Cool Thru	Ext Cool	A	A1	D	L	Price
MUR0040125	Radial Driven Tool ER25	ER25	1:1	6000		X	73.16				\$2,425
MUR0040225	Radial Driven Tool ER25 Cool Thru*	ER25	1:1	6000	X	X	88.16				\$3,175
MUR0040325	Radial Driven Tool ERA25	ERA25	1:1	6000		X	59.5				\$2,425
MUR0040425	Radial Driven Tool ERA25 Cool Thru*	ERA25	1:1	6000	X	X	74.5				\$3,175
MUR0040132	Radial Driven Tool ER32	ER32	1:1	6000		X	76.16				\$2,425
MUR0040232	Radial Driven Tool ER32 Cool Thru*	ER32	1:1	6000	X	X	91.16				\$3,175
MUR0040516	Radial Driven Tool 16x17mm	16x17	1:1	6000		X		54.5	16	17	\$2,750

*Coolant Thru tools are designed for 400 psi MAX.
They require 5 Micron Filtration and **CANNOT** be run dry.

MD60 - MD120

DRIVEN

AXIAL DRIVEN TOOL H=100mm **New**

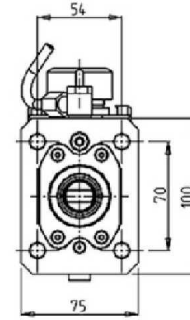
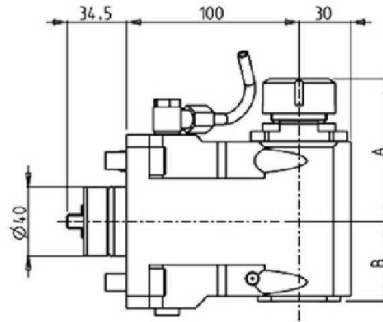
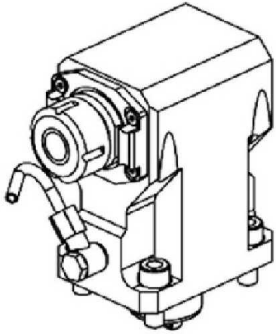

Part Number	Description	Spindle	I	RPM	Cool Thru	Ext Cool	A	B	Price
MUR0080125	Axial Driven Tool ER25	ER25	1:1	6000		X	82.36	46	\$4,295
MUR0080225	Axial Driven Tool ER25 Cool Thru*	ER25	1:1	6000	X	X	82.36	56	\$4,795

* Coolant Thru tools are designed for 1000 psi.
They require 5 Micron Filtration and **CANNOT** be run dry.

AXIAL GEARED-UP 1:2 DRIVEN TOOL H=100mm **New**

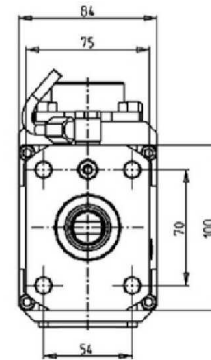
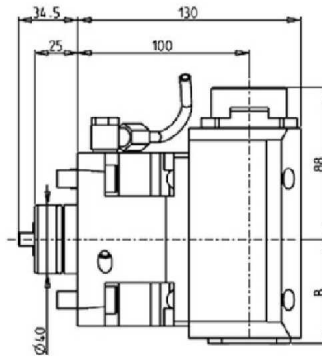
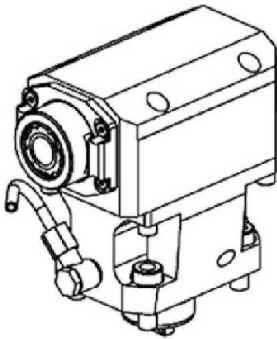

Part Number	Description	Spindle	I	RPM	Cool Thru	Ext Cool	B	Price
MUR0150325	Axial Geared-Up 1:2 ERA25	ERA25	1:2	12000		X	60	\$4,595
MUR0150425	Axial Geared-Up 1:2 ERA25 Cool Thru*	ERA25	1:2	12000	X	X	70	\$5,095

* Coolant Thru tools are designed for 1000 psi.
They require 5 Micron Filtration and **CANNOT** be run dry.

MD60 - MD120

DRIVEN

(0-180) ADJUSTABLE ANGLE DRIVEN TOOL H=74mm

It is not possible to make machining operations at the center of the part with tool oriented at 0° or at 180°

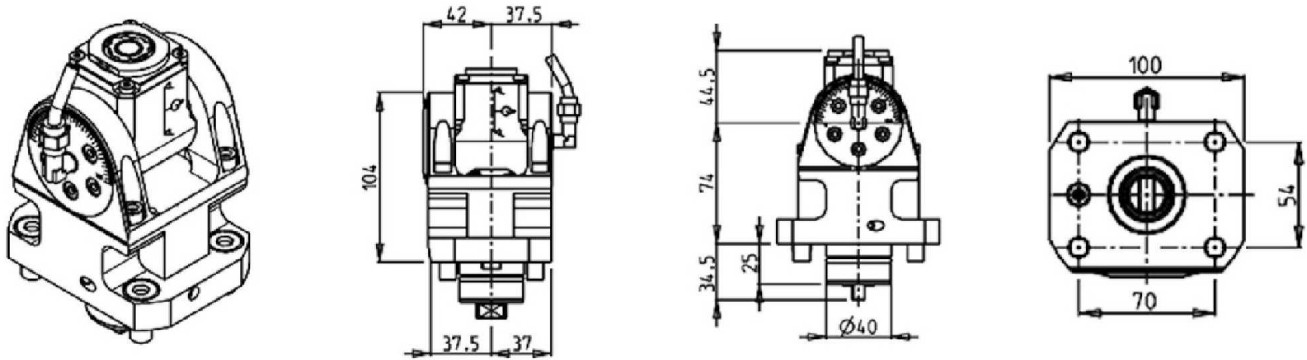

Part Number	Description	Spindle	I	RPM	Reversible	Cool Thru	Ext Cool	Price
MUR0060116	(0-180) Adj. Angle Driven Tool ERA16	ERA16	1:1	6000	X		X	\$7,150
MUR0060216	(0-180) Adj. Angle Driven Tool ERA16 Cool Thru*	ERA16	1:1	6000	X	X	X	\$7,995

* Coolant Thru tools are designed for 1000 psi.
They require 5 Micron Filtration and **CANNOT** be run dry.

Note :

Wrenches are provided with the purchase of Specialty Toolholders

MD60 - MD120

STATIC

RADIAL SINGLE STATIC TOOL New

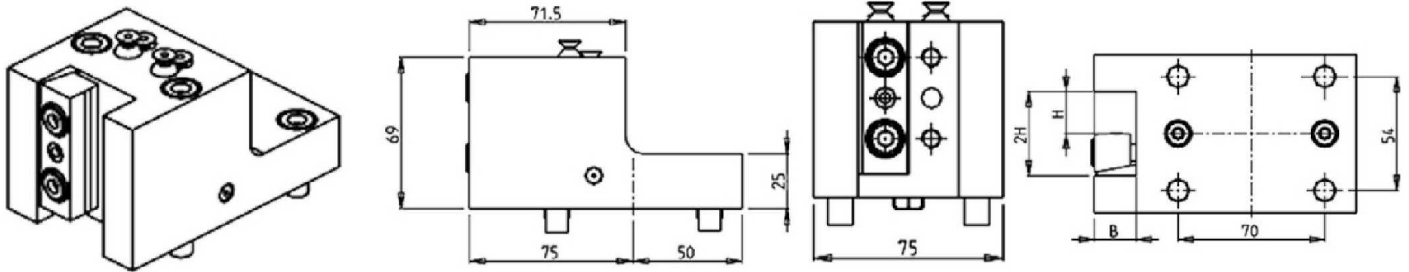

Part Number	Description	# of Tools	Cool Thru	Ext Cool	Dimensions	B	H	Price
MUR0162000	Radial Single Static Tool 20mm	1		X	mm	20	20	\$750
MUR0162010	Radial Single Static Tool 20mm Cool Thru*	1	X	X	mm	20	20	\$895

RADIAL BLADE HOLDER WITH BLADE KIT New

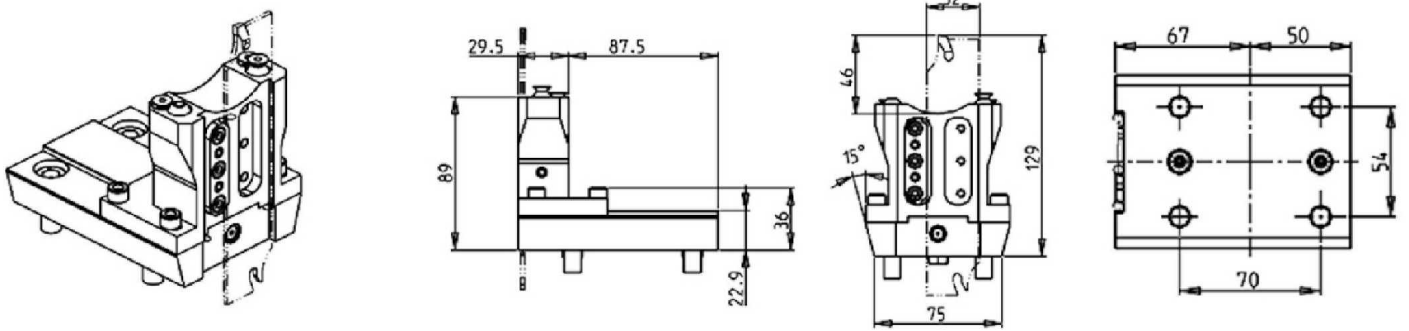

Part Number	Description	# of Tools	Reversible	Ext Cool	Price
MUR0190132	Radial Blade Holder with Blade Kit	1	X	X	\$1,050
BLADEKIT	Blade Kit: 1 Blade, 10 Inserts				\$395

RADIAL BLADE HOLDER WITH INTERNAL COOLANT - BLADE KIT NOT INCLUDED New

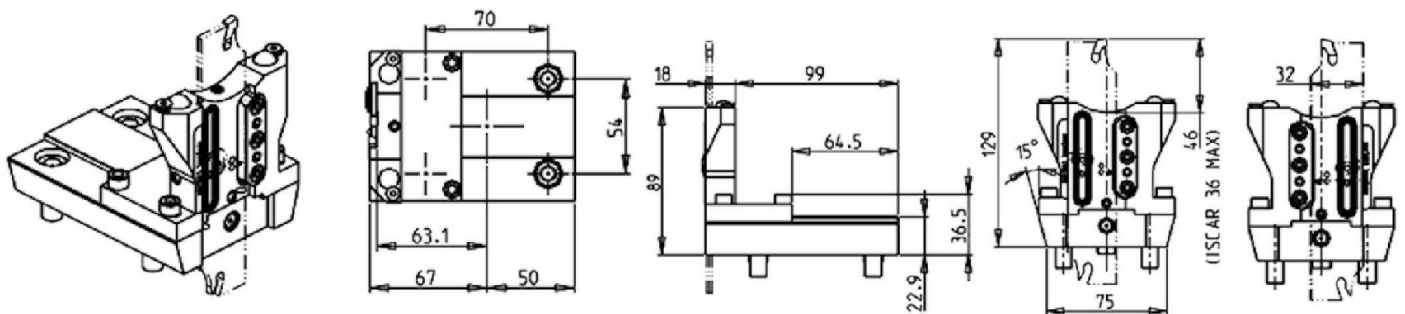

Part Number	Description	# of Tools	Ext Cool	Cool Thru	Price
MUR0200132R	Radial Blade Holder Cool Thru (Right Hand)	1	X	X	\$995
MUR0200132L	Radial Blade Holder Cool Thru (Left Hand)	1	X	X	\$995
COOL THRU BLADEKIT	Blade Kit: 1 Blade, 10 Inserts				\$550

MD60 - MD120

STATIC

AXIAL SINGLE STATIC TOOL **New**

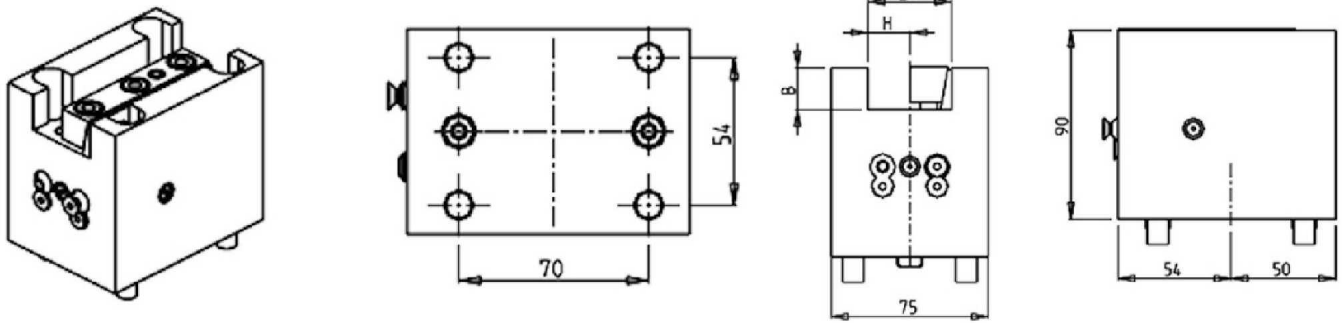

Part Number	Description	# of Tools	Cool Thru	Ext Cool	Dimensions	B	H	Price
MUR0172000	Axial Single Static Tool 20mm	1		X	mm	20	20	\$775
MUR0172010	Axial Single Static Tool 20mm Cool Thru*	1	X	X	mm	20	20	\$925

AXIAL SINGLE BORING BAR HOLDER H=95mm **New**

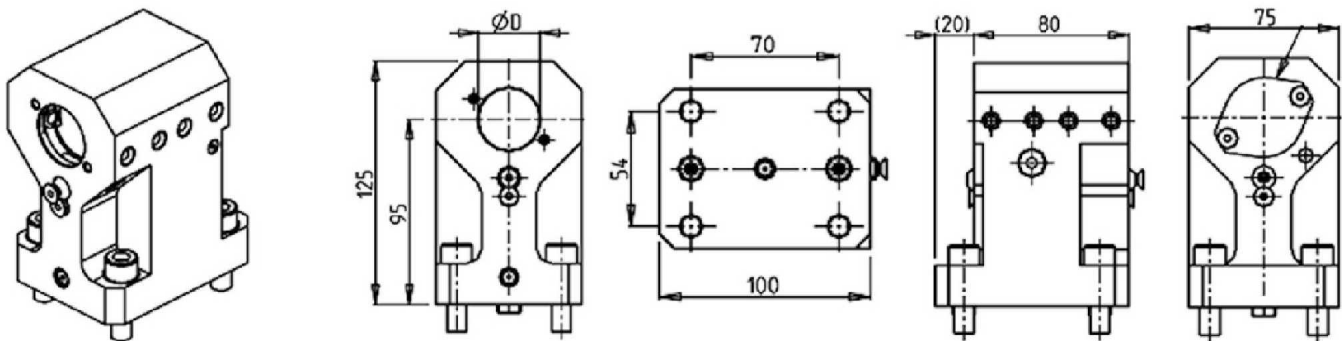

Part Number	Description	# of Tools	Reversible	Cool Thru	Ext Cool	Dimensions	D	Price
MUR0183200	Axial Single BBH 32mm	1	X	X	X	mm	32	\$825
KIT1000001	Plug for 32mm or 1-1/4" BBH to Make Cool Thru							\$75

MT100 15ST.

DRIVEN

RADIAL REINFORCED DRIVEN TOOL New

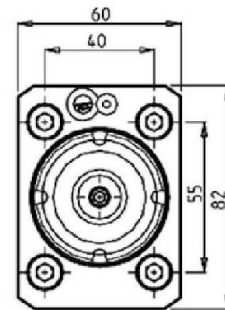
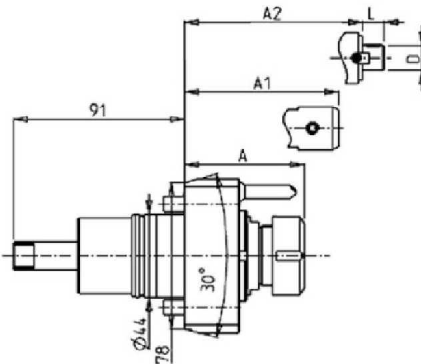
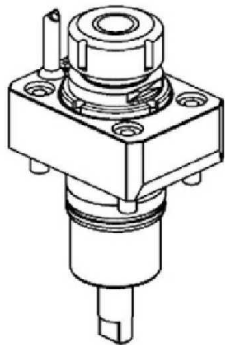

Part Number	Description	Spindle	I	RPM	Cool Thru	Ext Cool	A	A1	A2	D	L	Price
NKM0690520	Radial Driven Tool ERA20	ERA20	1:1	6000		X	43					\$1,475
NKM0690620	Radial Driven Tool ERA20 Cool Thru*	ERA20	1:1	6000	X	X	49					\$2,250
NKM0690125	Radial Driven Tool ER25	ER25	1:1	6000		X	63.66					\$1,475
NKM0690225	Radial Driven Tool ER25 Cool Thru*	ER25	1:1	6000	X	X	69.66					\$2,250
NKM0690716	Radial Mill Head \varnothing 16x17	\varnothing 16x17	1:1	6000		X			43	16	17	\$1,795
NKM0690316	Radial Driven Tool Weldon 16	Weldon 16	1:1	6000		X		50				\$1,795

*Coolant Thru tools are designed for 400 psi MAX.
They require 5 Micron Filtration and **CANNOT** be run dry.

QUICK CHANGE RADIAL MTSK DRIVEN TOOL

See Accessories for MTSK Adaptors

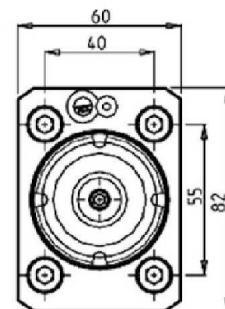
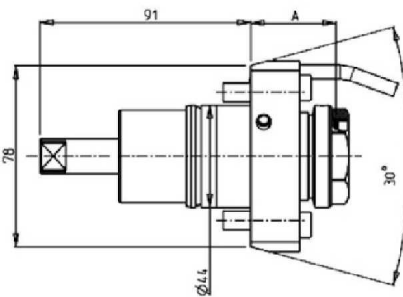
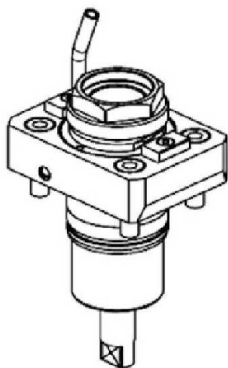

Part Number	Description	Spindle	I	RPM	Cool Thru	Ext Cool	A	Price
NKM1190132	Radial MTSK-32 Driven Tool	MTSK-32	1:1	6000		X	36.7	\$1,925
NKM1190232	Radial MTSK-32 Driven Tool Cool Thru*	MTSK-32	1:1	6000	X		44.7	\$2,525

*Coolant Thru tools are designed for 400 psi MAX.
They require 5 Micron Filtration and **CANNOT** be run dry.

MT100 15ST.

DRIVEN

RADIAL DRIVEN TOOL REDIRECTED IN Z BY 36mm New

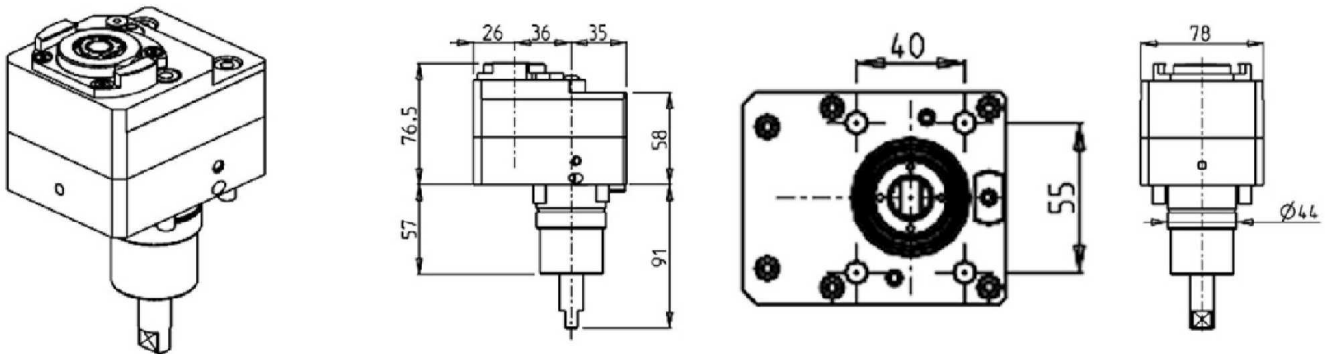

Part Number	Description	Spindle	I	RPM	Reversible	Cool Thru	Ext Cool	Price
NKM1690316	Radial Redirected ERA16	ERA16	1:1	6000	X		X	\$3,150
NKM1690416	Radial Redirected ERA16 Cool Thru*	ERA16	1:1	6000	X	X	X	\$3,495

* Coolant Thru tools are designed for 1000 psi.
They require 5 Micron Filtration and **CANNOT** be run dry.

RADIAL GEARED-DOWN 2:1 DRIVEN TOOL REDIRECTED IN Z BY 43mm New

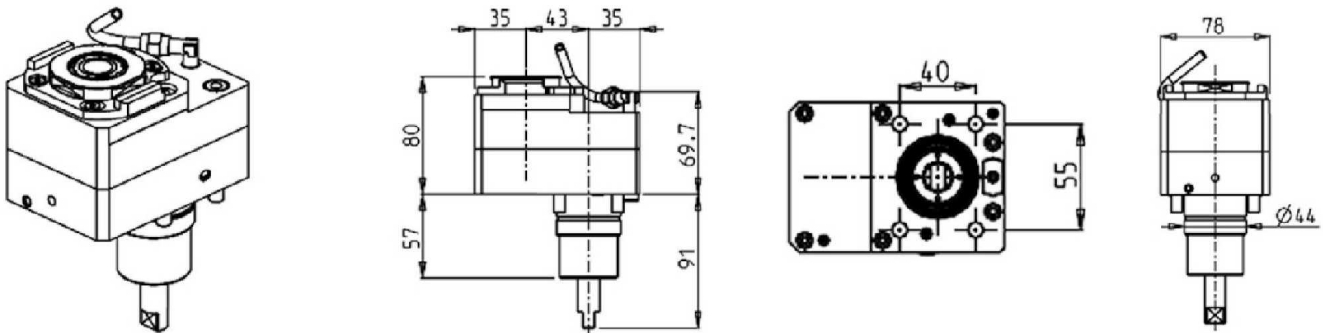

Part Number	Description	Spindle	I	RPM	Reversible	Cool Thru	Ext Cool	Price
NKM1580325	Radial Redirected Geared-Down 2:1 ERA25	ERA25	2:1	3000	X		X	\$3,295
NKM1580425	Radial Redirected Geared-Down 2:1 ERA25 Cool Thru*	ERA25	2:1	3000	X	X	X	\$3,795

* Coolant Thru tools are designed for 1000 psi.
They require 5 Micron Filtration and **CANNOT** be run dry.

MT100 15ST.

DRIVEN

RADIAL GEARED-DOWN 2:1 DRIVEN TOOL REDIRECTED IN Z BY 60mm New

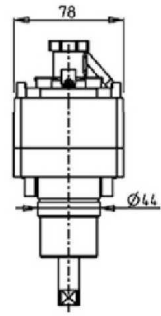
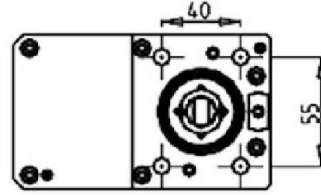
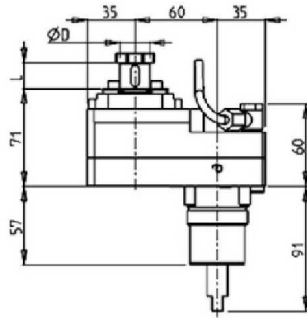
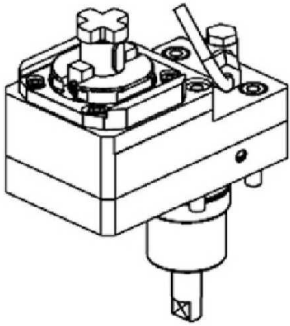

Part Number	Description	Spindle	I	RPM	Reversible	Ext Cool	D	L	Price
NKM1641617	Radial Redirected Geared-Down 2:1 \varnothing 16x17	\varnothing 16x17	2:1	3000	X	X	16	17	\$3,150
NKM1642219	Radial Redirected Geared-Down 2:1 \varnothing 22x19	\varnothing 22x19	2:1	3000	X	X	22	19	\$3,150

RADIAL GEARED-DOWN 3:1 DRIVEN TOOL REDIRECTED IN Z BY 60mm New

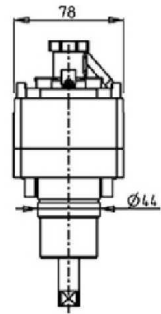
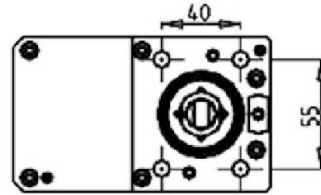
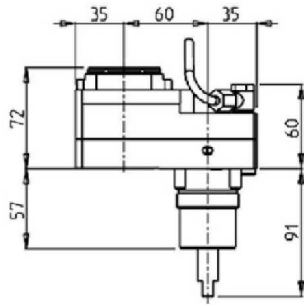
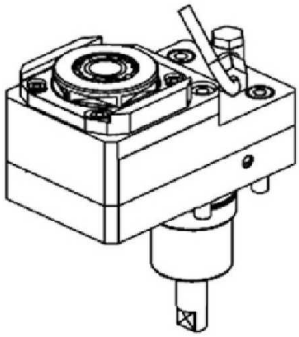

Part Number	Description	Spindle	I	RPM	Reversible	Ext Cool	D	L	Price
NKM1530325	Radial Redirected Geared-Down 3:1 ERA25	ERA25	3:1	2000	X	X			\$2,395

MT100 15ST.

DRIVEN

RADIAL GEARED-UP 1:2 DRIVEN TOOL REDIRECTED IN Z BY 36mm New

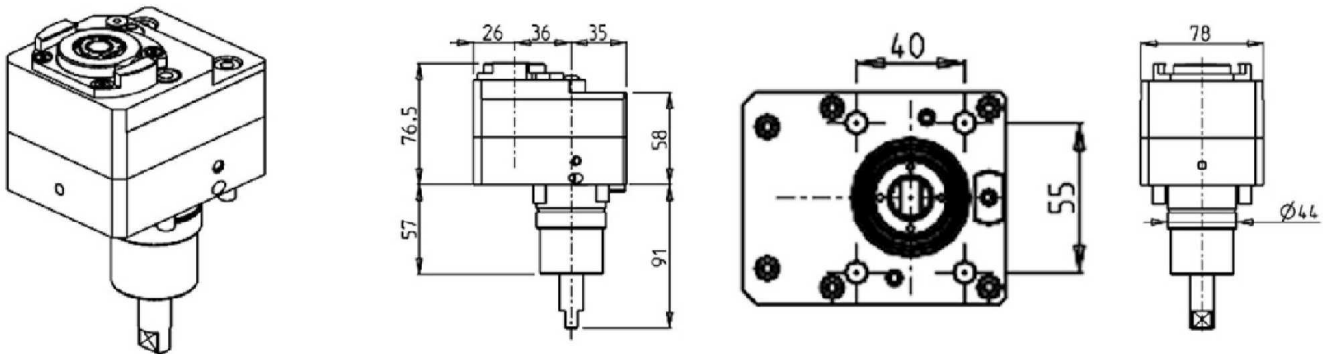

Part Number	Description	Spindle	I	RPM	Reversible	Cool Thru	Ext Cool	Price
NKM1691316	Radial Redirected Geared-Up 1:2 ERA16	ERA16	1:2	12000	X		X	\$3,295
NKM1691416	Radial Redirected Geared-Up 1:2 ERA16 Cool Thru*	ERA16	1:2	12000	X	X	X	\$3,775

* Coolant Thru tools are designed for 1000 psi. They require 5 Micron Filtration and **CANNOT** be run dry.

RADIAL SINGLE SIDE TWIN HEAD DRIVEN TOOL IN Y

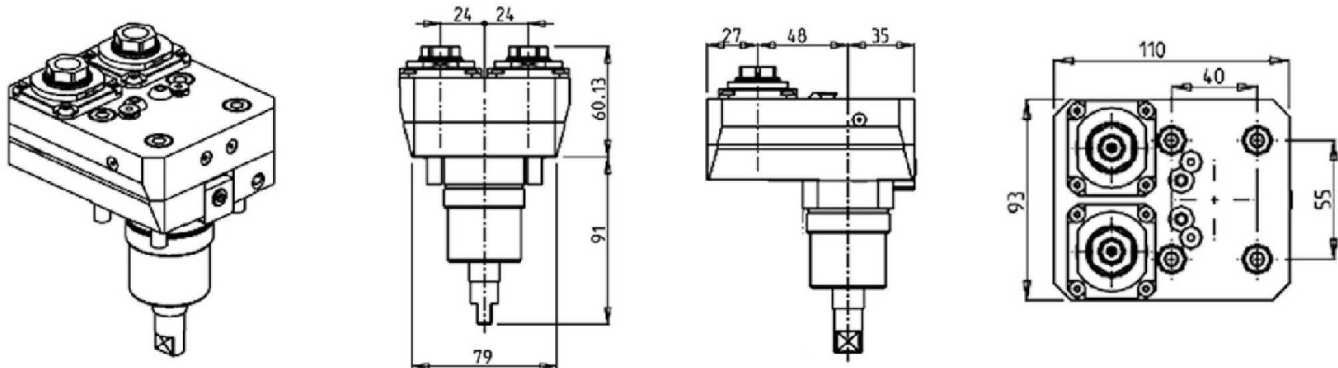

Part Number	Description	Spindle	I	RPM	Ext Cool	Price
NKM0190216	Radial Single Side Twin Head ERA16	ERA16	1:1	6000	X	\$4,225

MT100 15ST.

DRIVEN

AXIAL DRIVEN TOOL H=60mm

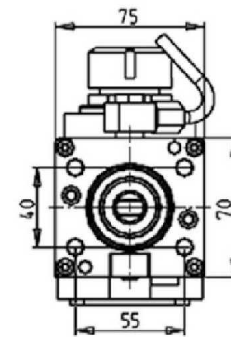
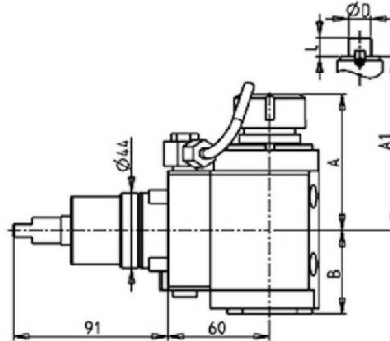
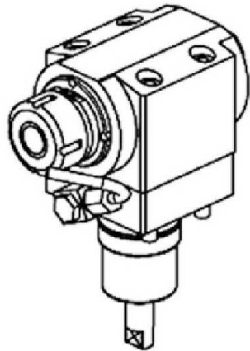

Part Number	Description	Spindle	I	RPM	Reversible	Cool Thru	Ext Cool	A	A1	B	D	L	Price
NKM0240520	Axial Driven Tool ERA20	ERA20	1:1	6000	X		X	69.23	49				\$2,850
NKM0240620	Axial Driven Tool ERA20 Cool Thru*	ERA20	1:1	6000	X	X	X	69.23	59				\$3,195
NKM0240125	Axial Driven Tool ER25	ER25	1:1	6000	X		X	80.16	49				\$2,875
NKM0240225	Axial Driven Tool ER25 Cool Thru*	ER25	1:1	6000	X	X	X	80.16	59				\$3,225
NKM0241617	Axial Driven Tool 16x17mm	16x17	1:1	6000	X		X		63	49	16	17	\$2,995
NKM0242219	Axial Driven Tool 22x19mm	22x19	1:1	6000	X		X		63	49	22	19	\$2,995

* Coolant Thru tools are designed for 1000 psi.
They require 5 Micron Filtration and **CANNOT** be run dry.

QUICK CHANGE AXIAL MTSK DRIVEN TOOL H=60mm

See Accessories for MTSK Adaptors

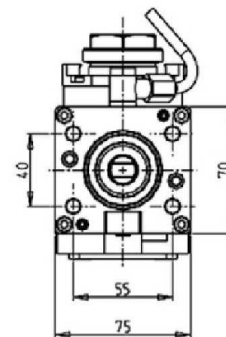
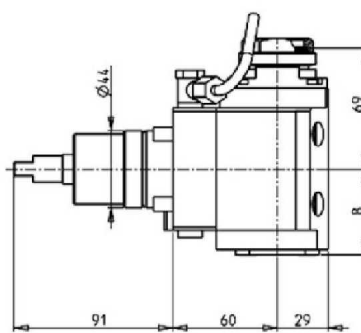
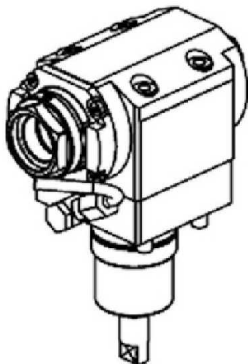

Part Number	Description	Spindle	I	RPM	Reversible	Cool Thru	Ext Cool	B	Price
NKM1200132	Axial MTSK-32 Driven Tool	MTSK-32	1:1	6000	X		X	49	\$3,495
NKM1200232	Axial MTSK-32 Driven Tool Cool Thru*	MTSK-32	1:1	6000	X	X	X	59	\$3,895

* Coolant Thru tools are designed for 1000 psi.
They require 5 Micron Filtration and **CANNOT** be run dry.

MT100 15ST.

DRIVEN

AXIAL GEARED-UP 1:2 DRIVEN TOOL

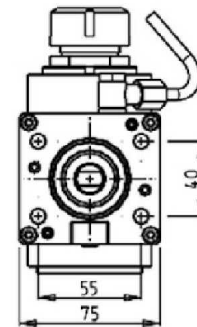
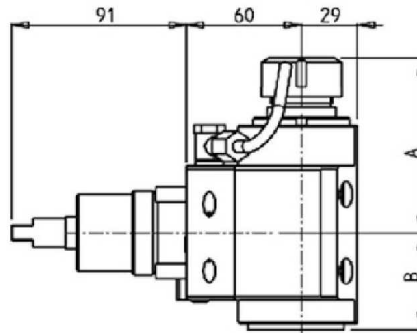

Part Number	Description	Spindle	I	RPM	Reversible	Cool Thru	Ext Cool	A	B	Price
NKM0710111	Axial Geared-Up 1:2 Driven Tool ER11	ER11	1:2	12000	X		X	83.6	50.5	\$3,350
NKM0710211	Axial Geared-Up 1:2 Driven Tool ER11 Cool Thru*	ER11	1:2	12000	X	X	X	83.6	60.5	\$3,695
NKM0710120	Axial Geared-Up 1:2 Driven Tool ER20	ER20	1:2	12000	X		X	92.16	50.5	\$3,350
NKM0710220	Axial Geared-Up 1:2 Driven Tool ER20 Cool Thru*	ER20	1:2	12000	X	X	X	92.16	60.5	\$3,695
NKM0710320	Axial Geared-Up 1:2 Driven Tool ERA20	ERA20	1:2	12000	X		X	72.5	50.5	\$3,325
NKM0710420	Axial Geared-Up 1:2 Driven Tool ERA20 Cool Thru*	ERA20	1:2	12000	X	X	X	72.5	60.5	\$3,675
NKM0710125	Axial Geared-Up 1:2 Driven Tool ER25	ER25	1:2	12000	X		X	91.16	50.5	\$3,350
NKM0710225	Axial Geared-Up 1:2 Driven Tool ER25 Cool Thru*	ER25	1:2	12000	X	X	X	91.16	60.5	\$3,695

* Coolant Thru tools are designed for 1000 psi. They require 5 Micron Filtration and **CANNOT** be run dry.

AXIAL GEARED-UP 1:3 REAR-SET DRIVEN TOOL H=65mm New

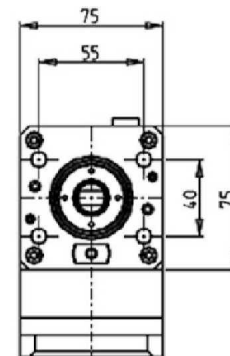
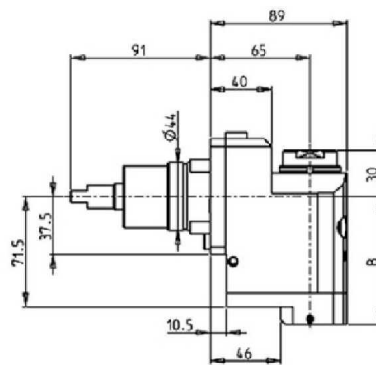
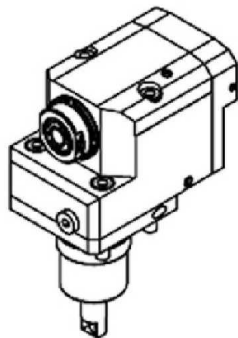

Part Number	Description	Spindle	I	RPM	Reversible	Cool Thru	Ext Cool	B	Price
NKM1650316	Axial Geared-Up 1:3 Rear-Set ERA16	ERA16	1:3	18000	X		X	70.5	\$4,450
NKM1650416	Axial Geared-Up 1:3 Rear-Set ERA16 Cool Thru*	ERA16	1:3	18000	X	X	X	83	\$4,975

*Coolant Thru tools are designed for 400 psi MAX. They require 5 Micron Filtration and **CANNOT** be run dry.

MT100 15ST.

DRIVEN

AXIAL DRIVEN TOOL FOR INTERNAL POLYGON-MAKING H=60mm

See Accessories for Mill Heads

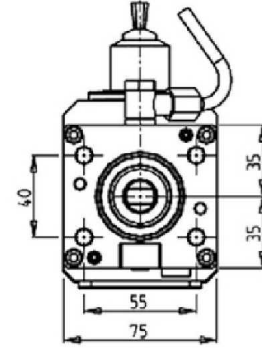
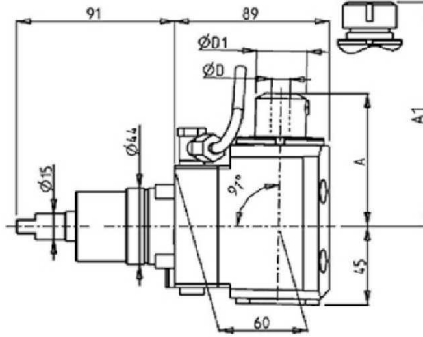
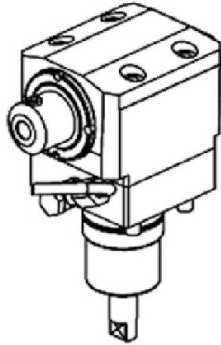

Part Number	Description	Spindle	I	RPM	Reversible	Ext Cool	A	A1	D	D1	Price
NKM1469125	Axial Driven Tool for Internal Polygon ER25	ER25	1:1	6000	X	X	82.4				\$4,625
NKM1469108	Axial Driven Tool for Internal Polygon Weldon 8	WELDON 8	1:1	6000	X	X	76.5	8	29		\$4,725
NKM1469110	Axial Driven Tool for Internal Polygon Weldon 10	WELDON 10	1:1	6000	X	X	76.5	10	29		\$4,725
NKM1469112	Axial Driven Tool for Internal Polygon Weldon 12	WELDON 12	1:1	6000	X	X	76.5	12	29		\$4,725
NKM1469116	Axial Driven Tool for Internal Polygon Weldon 16	WELDON 16	1:1	6000	X	X	73.5	16	32		\$4,725

AXIAL OPPOSITE FACE TWIN DRIVEN TOOL H=60mm

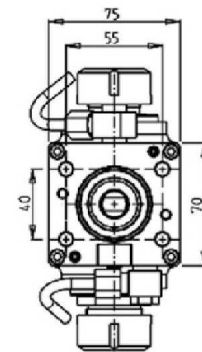
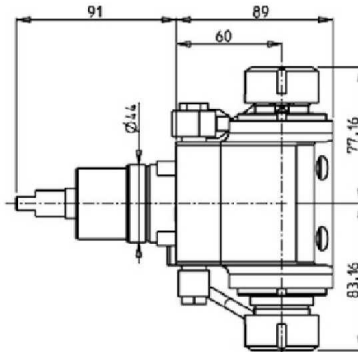
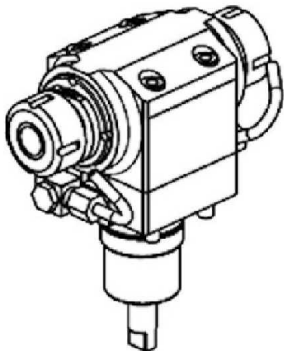

Part Number	Description	Spindle	I	RPM	Reversible	Ext Cool	Price
NKM0640225	Axial Opposite Face Twin Driven Tool ER25+ER25	ER25+ER25	1:1	6000	X	X	\$3,795

MT100 15ST.

DRIVEN

AXIAL SINGLE SIDE TWIN HEAD DRIVEN TOOL IN Y

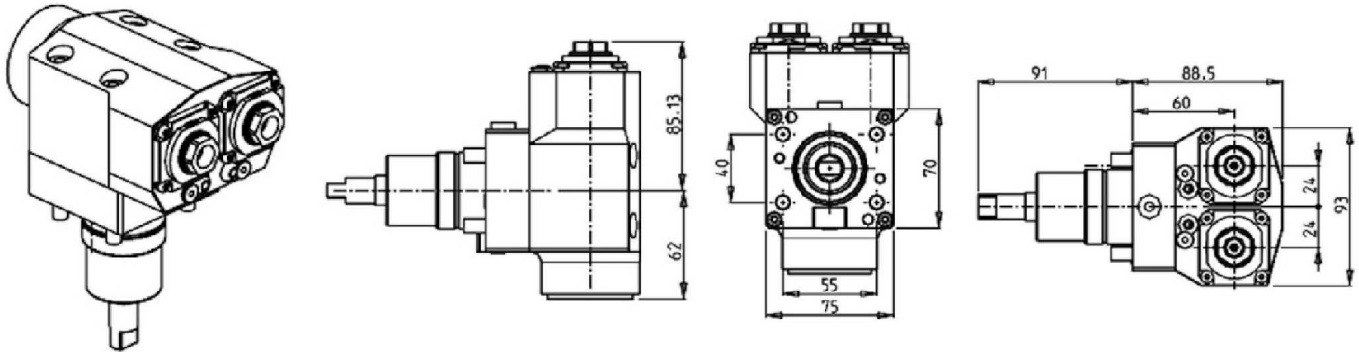

Part Number	Description	Spindle	I	RPM	Reversible	Ext Cool	Price
NKM0200216	Axial Single Side Twin Head Driven Tool ERA16	ERA16	1:1	6000	X	X	\$4,350

(0-180) ADJUSTABLE ANGLE DRIVEN TOOL

It is not possible to make machining operations at the center of the part with tool oriented at 0° or at 180°

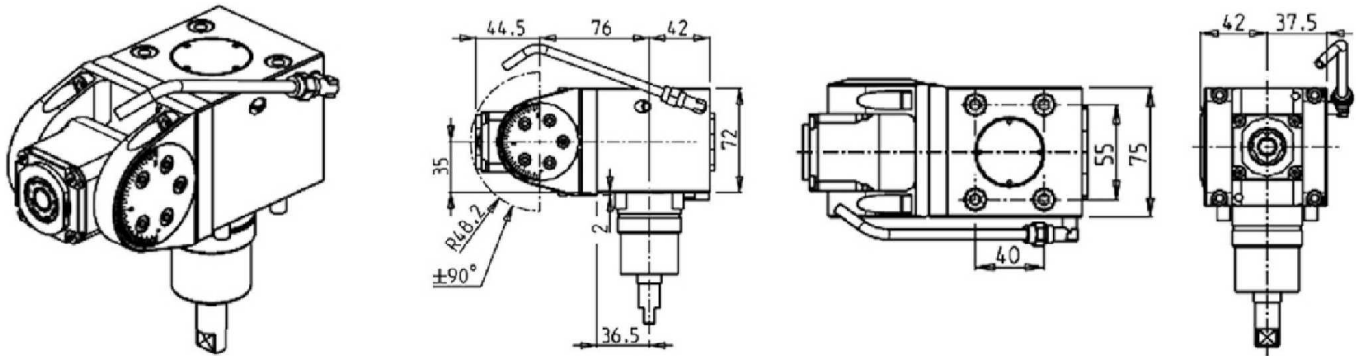

Part Number	Description	Spindle	I	RPM	Reversible	Ext Cool	Price
NKM0670316	(0-180) Adj. Angle Driven Tool ERA16	ERA16	1:1	6000	X	X	\$6,895

Note : Wrenches are provided with the purchase of Specialty Toolholders

MT100 15ST.

DRIVEN

DRIVEN GEAR HOBBER

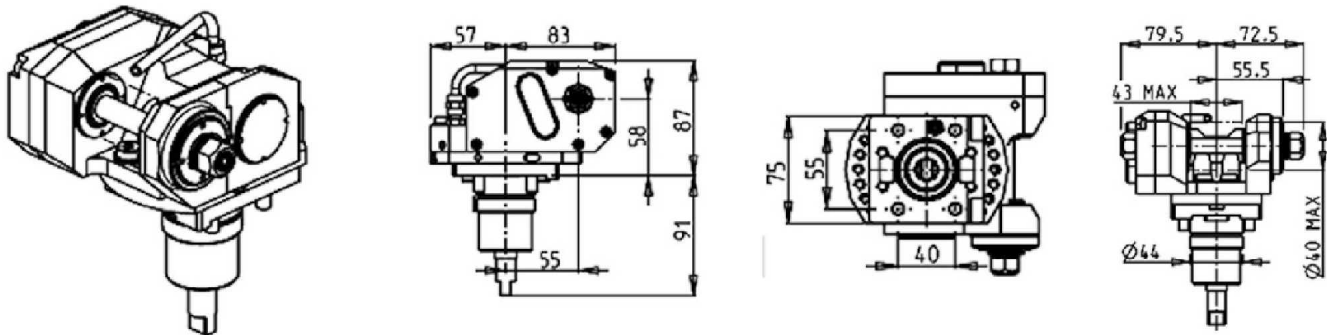

Part Number	Description	I	MAX RPM	Ext Cool	D (mm)	Price
NKM1071108	Gear Hobber 1:1 D=8mm	1:1	6000	X	8	\$7,595
NKM1071110	Gear Hobber 1:1 D=10mm	1:1	6000	X	10	\$7,595
NKM1071113	Gear Hobber 1:1 D=13mm	1:1	6000	X	13	\$7,595
NKM1071116	Gear Hobber 1:1 D=16mm	1:1	6000	X	16	\$7,595
NKM1072108	Gear Hobber 2:1 Geared Down D=8mm	2:1	3000	X	8	\$7,595
NKM1072110	Gear Hobber 2:1 Geared Down D=10mm	2:1	3000	X	10	\$7,595
NKM1072113	Gear Hobber 2:1 Geared Down D=13mm	2:1	3000	X	13	\$7,595
NKM1072116	Gear Hobber 2:1 Geared Down D=16mm	2:1	3000	X	16	\$7,595

Note : Wrenches are provided with the purchase of Specialty Toolholders

BROACHING/SLOTING DRIVEN TOOL 25mm STROKE H=65mm

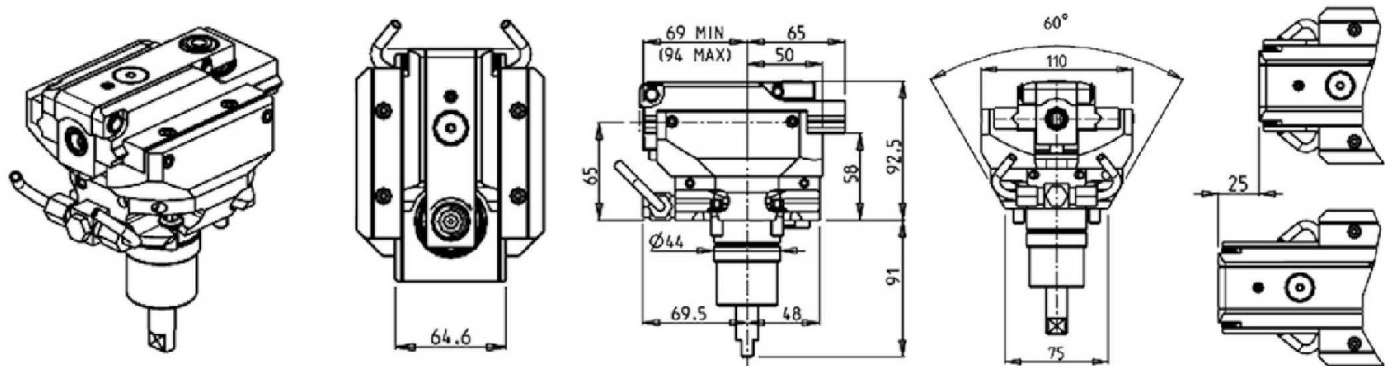

Part Number	Description	I	MAX RPM	Reversible	Ext Cool	Price
NKM1210200	Broaching/Slotting Driven Tool 25mm Stroke	4:1	2400	X	X	\$9,850

MT100 15ST.

STATIC

RADIAL SINGLE STATIC TOOL

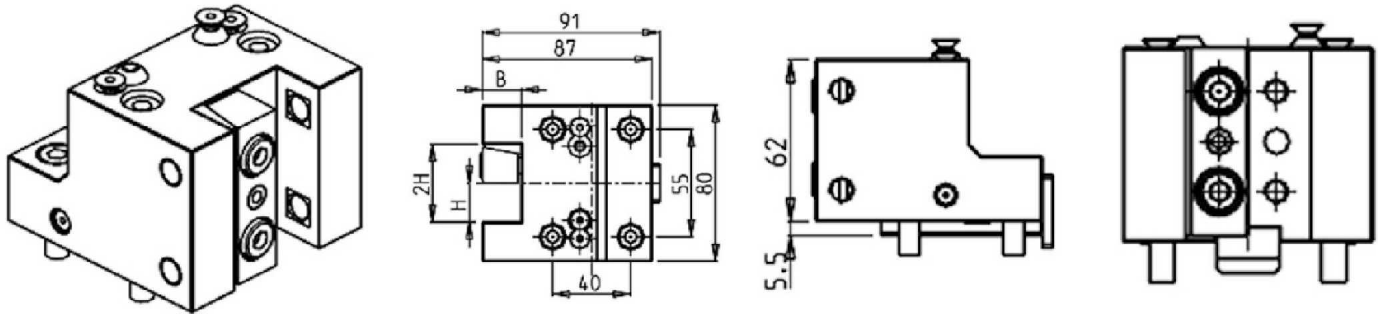

Part Number	Description	# of Tools	Reversible	Dimensions	B	H	Price
NKM0162010	Radial Single Static Tool 20mm	1	X	mm	20	20	\$575

RADIAL DOUBLE STATIC TOOL

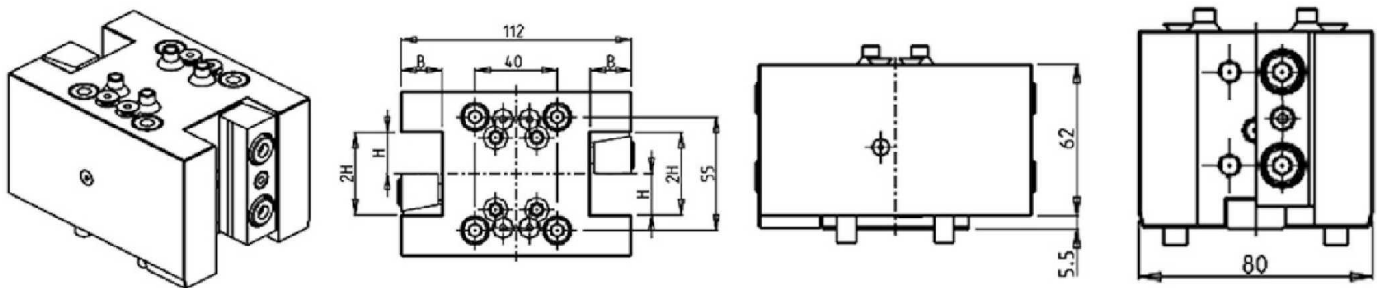

Part Number	Description	# of Tools	Reversible	Dimensions	B	H	Price
NKM0152010	Radial Double Static Tool 20mm	2	X	mm	20	20	\$650

RADIAL BLADE HOLDER WITH BLADE KIT

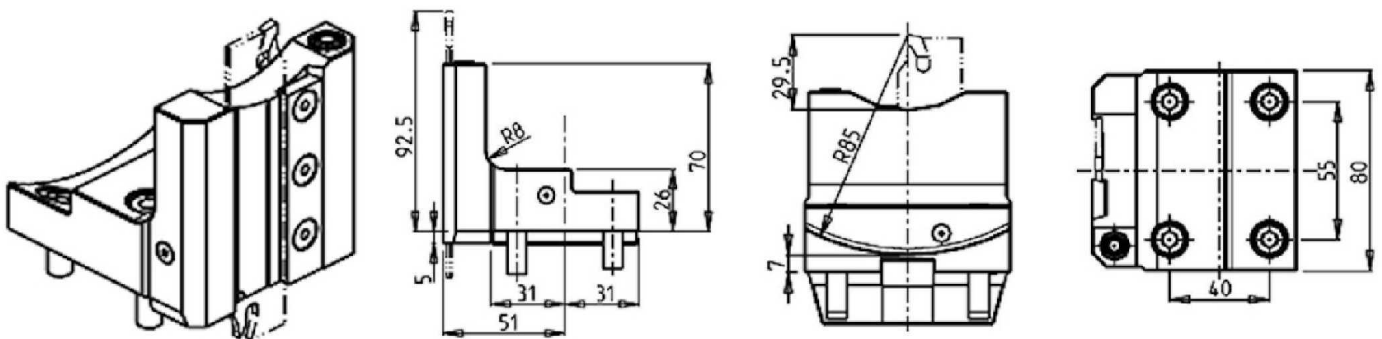

Part Number	Description	# of Tools	Price
NKM0170226	Radial Blade Holder with Blade Kit	1	\$775
BLADEKIT	Blade Kit: 1 Blade, 10 Inserts		\$395

MT100 15ST.

STATIC

AXIAL SINGLE STATIC TOOL

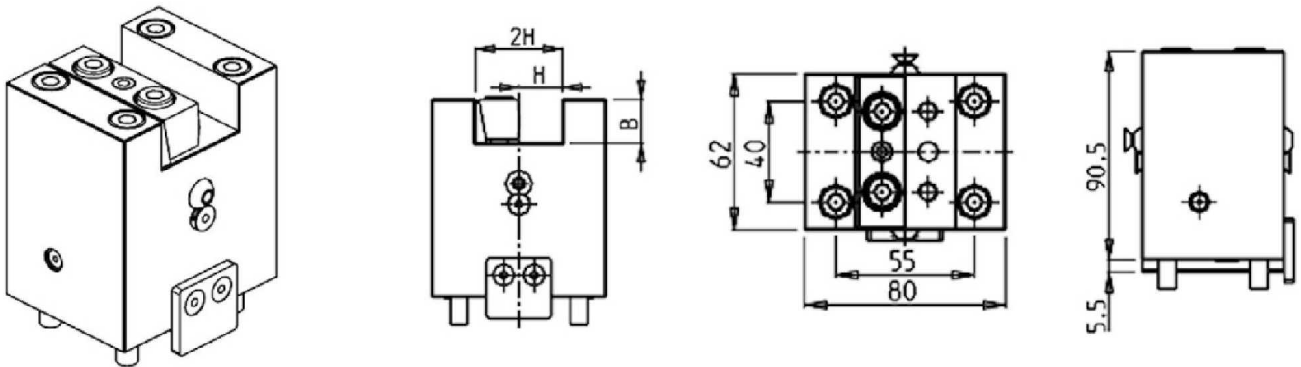

Part Number	Description	# of Tools	Reversible	Dimensions	B	H	Price
NKM0182010	Axial Single Static Tool 20mm	1	X	mm	20	20	\$75

AXIAL SINGLE BORING BAR HOLDER H=60mm

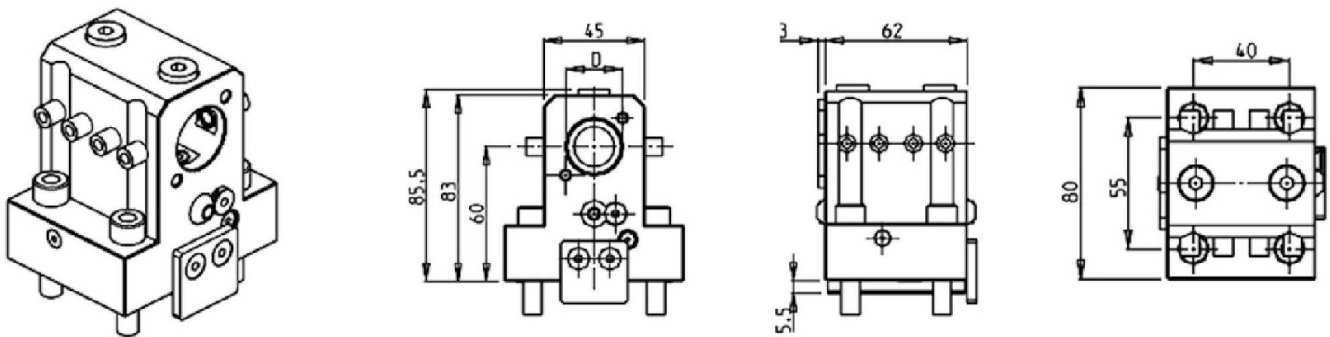

Part Number	Description	# of Tools	Reversible	Cool Thru	Ext Cool	Dimensions	D	Price
NKM0112540	Axial Single Boring Bar Holder 25mm	1	X	X	X	mm	25	\$550
KIT1000006	Plug for 25mm BBH to Make Cool Thru							\$75

AXIAL SINGLE BORING BAR HOLDER H=70mm

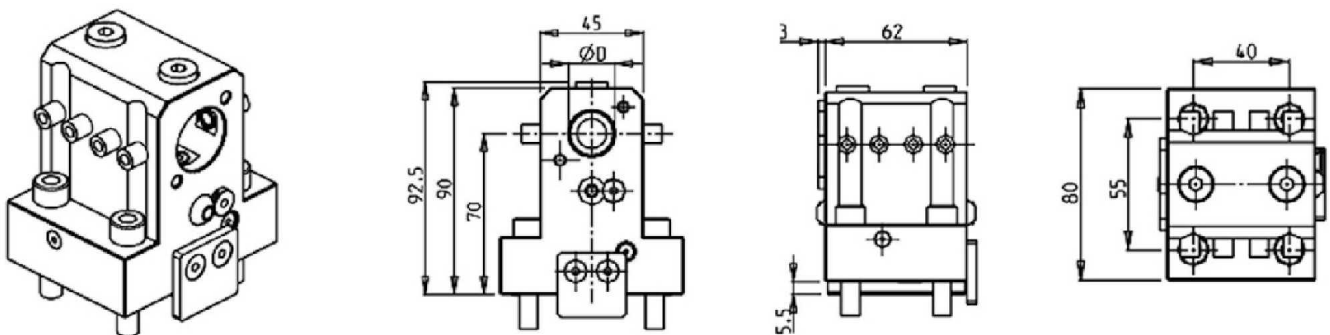

Part Number	Description	# of Tools	Reversible	Cool Thru	Ext Cool	Dimensions	D	Price
NKM0112550	Axial Single Boring Bar Holder 20mm	1	X	X	X	mm	20	\$550
KIT1000015	Plug for 20mm BBH to Make Cool Thru							\$75

ACCESSORIES

DRIVEN

MTSK-32 ER ADAPTORS

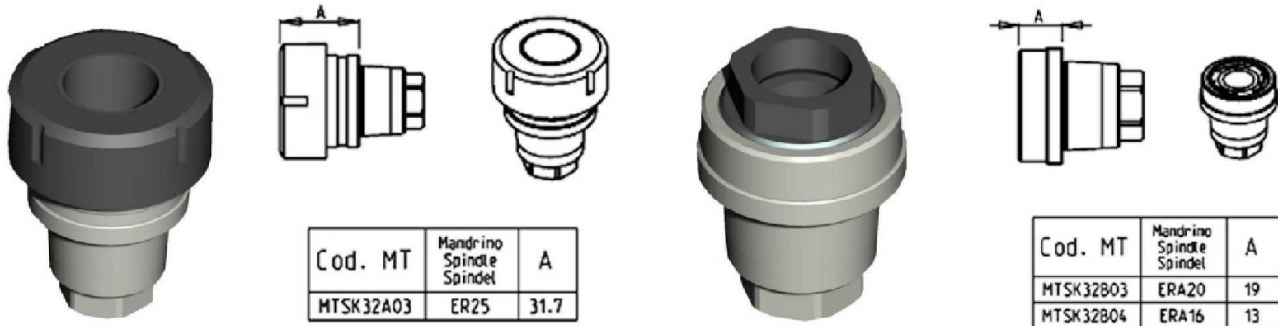

Cod. MT	Mandrino Spindel	A
MTSK32A03	ER25	31.7

Cod. MT	Mandrino Spindel	A
MTSK32B03	ERA20	19
MTSK32B04	ERA16	13

Part Number	Description	Spindle	A	Price
MTSK32B04	MTSK-32 Adaptor ERA16	ERA16	13	\$295
MTSK32B03	MTSK-32 Adaptor ERA20	ERA20	19	\$295
MTSK32A03	MTSK-32 Adaptor ER25	ER25	31.7	\$295

MTSK-32 MILL ADAPTORS

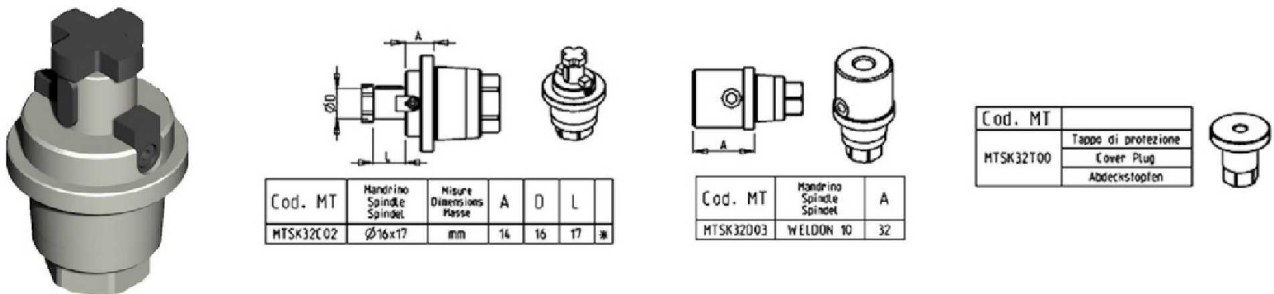

Cod. MT	Mandrino Spindel	Measure Dimensions	A	D	L
MTSK32C02	Ø16x17	mm	14	16	17

Cod. MT	Mandrino Spindel	A
MTSK32D03	WELDON 10	32

Cod. MT	Tappe di protezione
MTSK32T00	Cover Plug
	Abdeckstopfen

Part Number	Description	Spindle	Dimensions	A	D	L	Price
MTSK32C02	MTSK-32 Adaptor Mill Ø16x17	Ø16x17	mm	14	16	17	\$295
MTSK32D03	MTSK-32 Adaptor Mill Weldon 10	Weldon 10		32			\$295
MTSK32T00	MTSK-32 Cover Plug						\$150

ACCESSORIES

DRIVEN

POLYGON MAKING MILL HEAD (2 INSERTS)

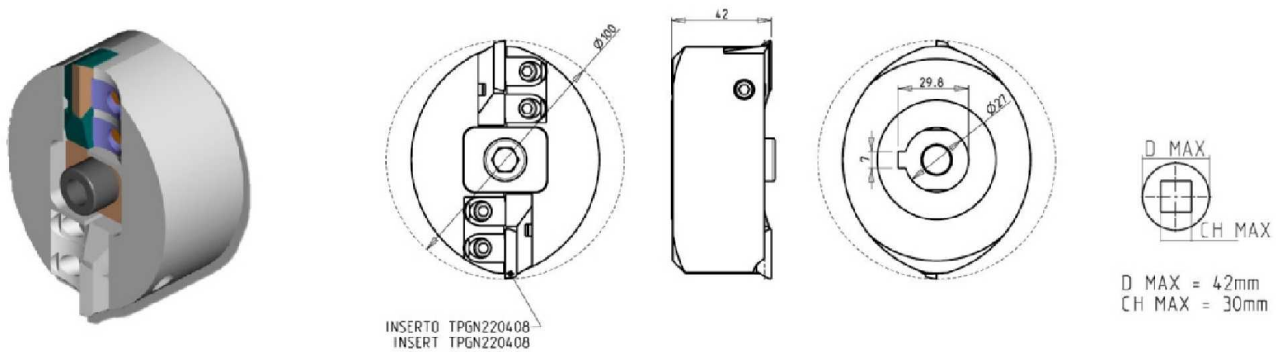

Part Number	Description	Price
P01Z20A100	2-Insert Polygon Making Head (with Inserts)	\$1,995
TPGN220408	10 Inserts for Polygon Making Heads	\$395

POLYGON MAKING MILL HEAD (3 INSERTS)

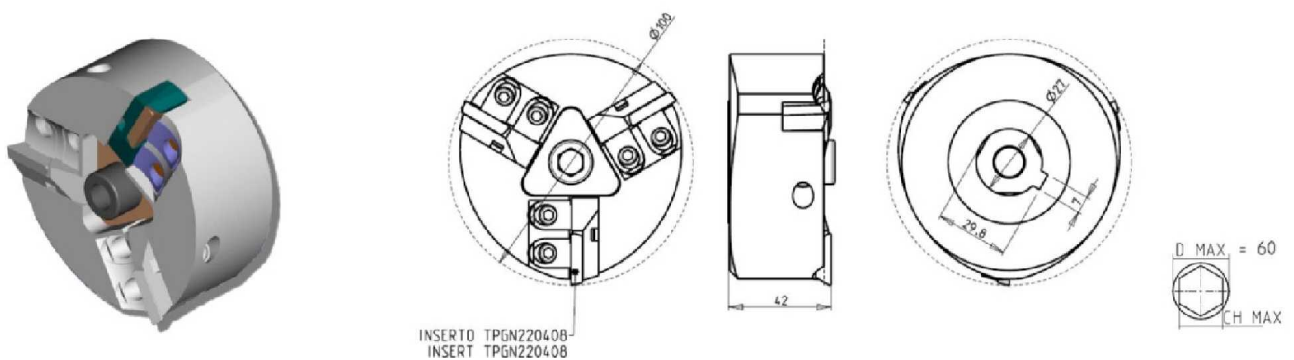

Part Number	Description	Price
P01Z30A100	2-Insert Polygon Making Head (with Inserts)	\$1,995
TPGN220408	10 Inserts for Polygon Making Heads	\$395

ER COLLETS

ER COLLET NUMBER	DESCRIPTION	MD LIST PRICE
ER20 SET	ER20 Collet Set (15 Collets)	\$ 330.00
ERX20 SET	ER20 Sealed Collet Set (13 Collets)	\$ 395.00
ER25 SET	ER25 Collet Set (19 Collets)	\$ 375.00
ERX25 SET	ER25 Sealed Collet Set (17 Collets)	\$ 475.00
ER32 SET	ER32 Collet Set (21 Collets)	\$ 425.00
ERX32 SET	ER32 Sealed Collet Set (21 Collets)	\$ 595.00
ER40 SET	ER40 Collet Set (29 Collets)	\$ 695.00
ERX40 SET	ER40 Sealed Collet Set (27 Collets)	\$ 850.00



Phone: (810) 632-4446 / Fax: (810) 632-4467

Table of Contents

Alphabetized Listing

((0-180) ADJUSTABLE ANGLE DRIVEN TOOL	19
	(0-180) ADJUSTABLE ANGLE DRIVEN TOOL H=74mm	3, 9
A		
	ACCESSORIES	23-24
	AXIAL DRIVEN TOOL FOR INTERNAL POLYGON-MAKING	
	H=60mm	18
	AXIAL DRIVEN TOOL H=100mm	2, 8
	AXIAL DRIVEN TOOL H=60mm	16
	AXIAL GEARED-UP 1:2 DRIVEN TOOL	17
	AXIAL GEARED-UP 1:2 DRIVEN TOOL H=100mm	8
	AXIAL GEARED-UP 1:3 REAR-SET DRIVEN TOOL H=65mm	17
	AXIAL OPPOSITE FACE TWIN DRIVEN TOOL H=60mm	18
	AXIAL SINGLE BORING BAR HOLDER H=60mm	22
	AXIAL SINGLE BORING BAR HOLDER H=70mm	22
	AXIAL SINGLE BORING BAR HOLDER H=95mm	6, 11
	AXIAL SINGLE SIDE TWIN HEAD DRIVEN TOOL IN Y	19
	AXIAL SINGLE STATIC TOOL	6, 11, 22
B		
	BROACHING/SLOTTING DRIVEN TOOL 25mm STROKE H=65mm	20
D		
	DRIVEN	1-4, 7-9, 12-20, 23-24
	DRIVEN GEAR HOBBER	4, 20
M		
	MD60 - MD120	7-11
	MT100 15ST.	12-22
	MT12 - MT200	1-6
	MTSK-32 ER ADAPTORS	23
	MTSK-32 MILL ADAPTORS	23
P		
	POLYGON MAKING MILL HEAD (2 INSERTS)	24
	POLYGON MAKING MILL HEAD (3 INSERTS)	24
Q		
	QUICK CHANGE AXIAL MTSK DRIVEN TOOL H=60mm	16
	QUICK CHANGE RADIAL MTSK DRIVEN TOOL	12
R		
	RADIAL BLADE HOLDER WITH BLADE KIT	5, 10
	RADIAL BLADE HOLDER WITH BLADE KIT	21
	RADIAL BLADE HOLDER WITH INTERNAL COOLANT - BLADE	
	KIT NOT INCLUDED	5, 10
	RADIAL DOUBLE STATIC TOOL	21
	RADIAL DRIVEN TOOL	1, 7
	RADIAL DRIVEN TOOL REDIRECTED IN Z BY 36mm	13
	RADIAL GEARED-DOWN 2:1 DRIVEN TOOL REDIRECTED IN Z	
	BY 43mm	13
	RADIAL GEARED-DOWN 2:1 DRIVEN TOOL REDIRECTED IN Z	
	BY 60mm	14
	RADIAL GEARED-DOWN 3:1 DRIVEN TOOL REDIRECTED IN Z	
	BY 60mm	14
	RADIAL GEARED-UP 1:2 DRIVEN TOOL REDIRECTED IN Z BY	
	36mm	15
	RADIAL REINFORCED DRIVEN TOOL	12
	RADIAL SINGLE SIDE TWIN HEAD DRIVEN TOOL IN Y	15
	RADIAL SINGLE STATIC TOOL	5, 10, 21
S		
	See Accessories for Mill Heads	18
	See Accessories for MTSK Adaptors	12, 16
	STATIC	5-6, 10-11, 21-22

Table of Contents

Part Number Index

B							
BLADEKIT	Blade Kit: 1 Blade, 10 Inserts New	5	MUR0200132L	Radial Blade Holder Cool Thru (Left Hand) New	5		
BLADEKIT	Blade Kit: 1 Blade, 10 Inserts New	10	MUR0200132L	Radial Blade Holder Cool Thru (Left Hand) New	10		
BLADEKIT	Blade Kit: 1 Blade, 10 Inserts New	21	MUR0200132R	Radial Blade Holder Cool Thru (Right Hand) New	10		
C			MUR0211108	Radial Blade Holder Cool Thru (Right Hand) New	5		
COOL THRU	Blade Kit: 1 Blade, 10 Inserts New	10	MUR0211110	Driven Gear Hobb 1:1 D=8mm New	4		
BLADEKIT			MUR0211110	Driven Gear Hobb 1:1 D=10mm New	4		
COOL THRU	Blade Kit: 1 Blade, 10 Inserts New	5	MUR0211113	Driven Gear Hobb 1:1 D=13mm New	4		
BLADEKIT			MUR0211116	Driven Gear Hobb 1:1 D=16mm New	4		
K			MUR0211155	Driven Gear Hobb 1:1 D=1/2" New	4		
KIT1000001	Plug for 32mm or 1-1/4" BBH to Make Cool Thru New	6	MUR0212108	Driven Gear Hobb Geared-Down 2:1 D=8mm New	4		
KIT1000001	Plug for 32mm or 1-1/4" BBH to Make Cool Thru New	11	MUR0212110	Driven Gear Hobb Geared-Down 2:1 D=10mm New	4		
KIT1000006	Plug for 25mm BBH to Make Cool Thru	22	MUR0212113	Driven Gear Hobb Geared-Down 2:1 D=13mm New	4		
KIT1000015	Plug for 20mm BBH to Make Cool Thru	22	MUR0212116	Driven Gear Hobb Geared-Down 2:1 D=16mm New	4		
M			MUR0212155	Driven Gear Hobb Geared-Down 2:1 D=1/2" New	4		
MTSK32A03	MTSK-32 Adaptor ER25	23	N				
MTSK32B03	MTSK-32 Adaptor ERA20	23	NKM0112540	Axial Single Boring Bar Holder 25mm	22		
MTSK32B04	MTSK-32 Adaptor ERA16	23	NKM0112550	Axial Single Boring Bar Holder 20mm	22		
MTSK32C02	MTSK-32 Adaptor Mill Ø16x17	23	NKM0152010	Radial Double Static Tool 20mm	21		
MTSK32D03	MTSK-32 Adaptor Mill Weldon 10	23	NKM0162010	Radial Single Static Tool 20mm	21		
MTSK32T00	MTSK-32 Cover Plug	23	NKM0170226	Radial Blade Holder with Blade Kit	21		
MUR0030125	Axial Driven Tool ER25	2	NKM0182010	Axial Single Static Tool 20mm	22		
MUR0030132	Axial Driven Tool ER32	2	NKM0190216	Radial Single Side Twin Head ERA16	15		
MUR0030140	Axial Driven Tool ER40	2	NKM0200216	Axial Single Side Twin Head Driven Tool ERA16	19		
MUR0030225	Axial Driven Tool ER25 Cool Thru*	2	NKM0240125	Axial Driven Tool ER25	16		
MUR0030232	Axial Driven Tool ER32 Cool Thru*	2	NKM0240225	Axial Driven Tool ER25 Cool Thru*	16		
MUR0030240	Axial Driven Tool ER40 Cool Thru*	2	NKM0240520	Axial Driven Tool ERA20	16		
MUR0030325	Axial Driven Tool ERA25	2	NKM0240620	Axial Driven Tool ERA20 Cool Thru*	16		
MUR0030425	Axial Driven Tool ERA25 Cool Thru*	2	NKM0241617	Axial Driven Tool 16x17mm	16		
MUR0030516	Axial Driven Tool 16x17mm	2	NKM0242219	Axial Driven Tool 22x19mm	16		
MUR0030522	Axial Driven Tool 22x19mm	2	NKM0640225	Axial Opposite Face Twin Driven Tool ER25+ER25	18		
MUR0030527	Axial Driven Tool 27x21mm	2					
MUR0040125	Radial Driven Tool ER25	7	NKM0670316	(0-180) Adj. Angle Driven Tool ERA16	19		
MUR0040132	Radial Driven Tool ER32	7	NKM0690125	Radial Driven Tool ER25	12		
MUR0040225	Radial Driven Tool ER25 Cool Thru*	7	NKM0690225	Radial Driven Tool ER25 Cool Thru*	12		
MUR0040232	Radial Driven Tool ER32 Cool Thru*	7	NKM0690316	Radial Driven Tool Weldon 16 New	12		
MUR0040325	Radial Driven Tool ERA25	7	NKM0690520	Radial Driven Tool ERA20	12		
MUR0040425	Radial Driven Tool ERA25 Cool Thru*	7	NKM0690620	Radial Driven Tool ERA20 Cool Thru*	12		
MUR0040516	Radial Driven Tool 16x17mm	7	NKM0690716	Radial Mill Head Ø16x17 New	12		
MUR0050125	Radial Driven Tool ER25	1	NKM0710111	Axial Geared-Up 1:2 Driven Tool ER11	17		
MUR0050132	Radial Driven Tool ER32	1	NKM0710120	Axial Geared-Up 1:2 Driven Tool ER20	17		
MUR0050225	Radial Driven Tool ER25 Cool Thru*	1	NKM0710125	Axial Geared-Up 1:2 Driven Tool ER25	17		
MUR0050232	Radial Driven Tool ER32 Cool Thru*	1	NKM0710211	Axial Geared-Up 1:2 Driven Tool ER11 Cool Thru*	17		
MUR0050325	Radial Driven Tool ERA25	1					
MUR0050425	Radial Driven Tool ERA25 Cool Thru*	1	NKM0710220	Axial Geared-Up 1:2 Driven Tool ER20 Cool Thru*	17		
MUR0050516	Radial Driven Tool 16x17mm	1					
MUR0060116	(0-180) Adj. Angle Driven Tool ERA16	9	NKM0710225	Axial Geared-Up 1:2 Driven Tool ER25 Cool Thru*	17		
MUR0060216	(0-180) Adj. Angle Driven Tool ERA16 Cool Thru*	9					
MUR0070116	(0-180) Adj. Angle Driven Tool ERA16	3	NKM0710320	Axial Geared-Up 1:2 Driven Tool ERA20	17		
MUR0070216	(0-180) Adj. Angle Driven Tool ERA16 Cool Thru*	3	NKM0710420	Axial Geared-Up 1:2 Driven Tool ERA20 Cool Thru*	17		
MUR0080125	Axial Driven Tool ER25 New	8	NKM1071108	Gear Hobber 1:1 D=8mm	20		
MUR0080225	Axial Driven Tool ER25 Cool Thru* New	8	NKM1071110	Gear Hobber 1:1 D=10mm	20		
MUR0150325	Axial Geared-Up 1:2 ERA25 New	8	NKM1071113	Gear Hobber 1:1 D=13mm	20		
MUR0150425	Axial Geared-Up 1:2 ERA25 Cool Thru* New	8	NKM1071116	Gear Hobber 1:1 D=16mm	20		
MUR0162000	Radial Single Static Tool 20mm New	10	NKM1072108	Gear Hobber 2:1 Geared Down D=8mm	20		
MUR0162000	Radial Single Static Tool 20mm New	5	NKM1072110	Gear Hobber 2:1 Geared Down D=10mm	20		
MUR0162010	Radial Single Static Tool 20mm Cool Thru* New	5	NKM1072113	Gear Hobber 2:1 Geared Down D=13mm	20		
MUR0162010	Radial Single Static Tool 20mm Cool Thru* New	10	NKM1072116	Gear Hobber 2:1 Geared Down D=16mm	20		
MUR0172000	Axial Single Static Tool 20mm New	6	NKM1190132	Radial MTSK-32 Driven Tool	12		
MUR0172000	Axial Single Static Tool 20mm New	11	NKM1190232	Radial MTSK-32 Driven Tool Cool Thru*	12		
MUR0172010	Axial Single Static Tool 20mm Cool Thru* New	11	NKM1200132	Axial MTSK-32 Driven Tool	16		
MUR0172010	Axial Single Static Tool 20mm Cool Thru* New	6	NKM1200232	Axial MTSK-32 Driven Tool Cool Thru*	16		
MUR0183200	Axial Single BBH 32mm New	6	NKM1210200	Broaching/Slotting Driven Tool 25mm Stroke	20		
MUR0183200	Axial Single BBH 32mm New	11	NKM1469108	Axial Driven Tool for Internal Polygon Weldon 8	18		
MUR0190132	Radial Blade Holder with Blade Kit New	10	NKM1469110	Axial Driven Tool for Internal Polygon Weldon 10	18		
MUR0190132	Radial Blade Holder with Blade Kit New	5					

Table of Contents

Part Number Index

NKM1469112	Axial Driven Tool for Internal Polygon Weldon 12	18
NKM1469116	Axial Driven Tool for Internal Polygon Weldon 16	18
NKM1469125	Axial Driven Tool for Internal Polygon ER25	18
NKM1530325	Radial Redirected Geared-Down 3:1 ERA25 New	14
NKM1580325	Radial Redirected Geared-Down 2:1 ERA25 New	13
NKM1580425	Radial Redirected Geared-Down 2:1 ERA25 Cool Thru* New	13
NKM1641617	Radial Redirected Geared-Down 2:1 Ø16x17 New	14
NKM1642219	Radial Redirected Geared-Down 2:1 Ø22x19 New	14
NKM1650316	Axial Geared-Up 1:3 Rear-Set ERA16 New	17
NKM1650416	Axial Geared-Up 1:3 Rear-Set ERA16 Cool Thru* New	17
NKM1690316	Radial Redirected ERA16 New	13
NKM1690416	Radial Redirected ERA16 Cool Thru* New	13
NKM1691316	Radial Redirected Geared-Up 1:2 ERA16 New	15
NKM1691416	Radial Redirected Geared-Up 1:2 ERA16 Cool Thru* New	15
P		
P01Z20A100	2-Insert Polygon Making Head (with Inserts)	24
P01Z30A100	2-Insert Polygon Making Head (with Inserts)	24
T		
TPGN220408	10 Inserts for Polygon Making Heads	24
TPGN220408	10 Inserts for Polygon Making Heads	24